

An aerial photograph of a small, dark-roofed cabin with a large glass front porch, situated in a lush forest. A stone path leads from the cabin to a rectangular swimming pool with a tiled deck. The trees are in full autumn foliage, displaying vibrant yellows, oranges, and reds. In the background, rolling hills are visible under a sunset sky with soft, golden light and scattered clouds.

Hudson Woods

Handbook

Hudson Woods

Handbook





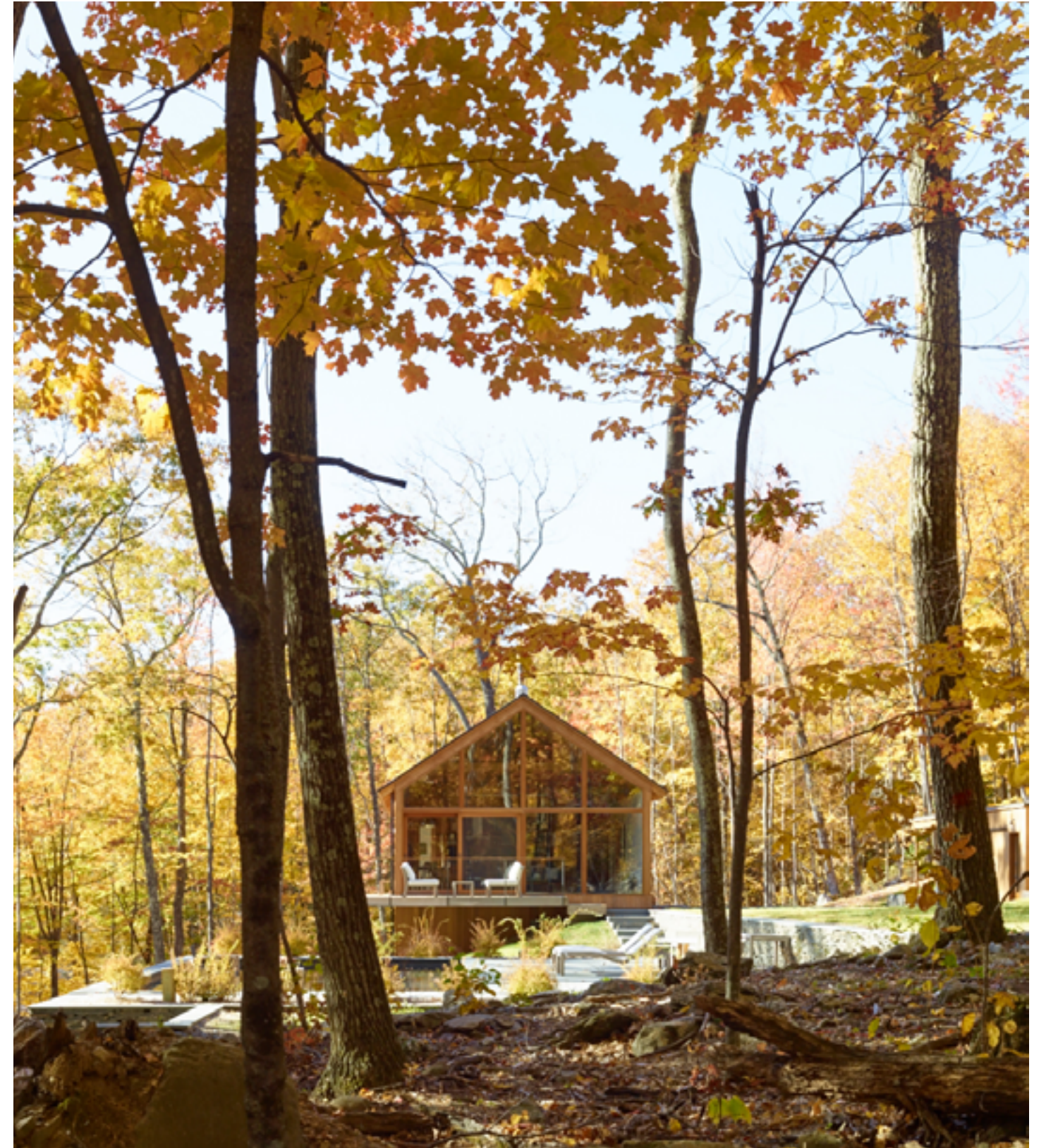





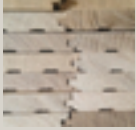





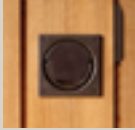



LANG

285 West Broadway Suite 300
New York New York 10013





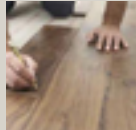





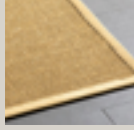

Contents

HUDSON WOODS PARTNERS:

- 01  Allegheny Mountain hardwood flooring
- 03  Andrew Becker Design custom metal components
- 07  Samuel Moyer custom kitchen pantry
- 09  Dzeirlenga F+U furniture
- 11  Wittus Stoves wood-burning stoves
- 15  EcoSupply windows
- 17  Fisher & Paykel appliances
- 19  Sun Valley Bronze hardware
- 23  FERN furniture
- 25  Michael Robbins furniture
- 27  Workstead decorative lighting
- 29  Allied Maker decorative lighting
- 33  Trueform custom concrete
- 35  Walker Zanger tile
- 37  M. Teixeira Soapstone countertops
- 41  Heath Ceramics tile
- 43  Carl Hansen & Søn furniture
- 45  Modernlink furniture
- 47  ERNEST NY outdoor furniture
- 51  WOCA Denmark finishing
- 53  Calico Wallaper decorative

HUDSON WOODS ASSEMBLIES:

- 55  Cloak carpet
- 57  USM Modular storage
- 61  Earth Designs landscape
- 65  ARRIVAL
- 69  NOURISH
- 77  BATHE
- 83  REPOSE
- 87  SWIM
- 95  STRUCTURE
- 101  RAILING

Introduction

A Community of Collaborators

Wherever you might be reading this, you're holding a piece of Hudson Woods in your hands.

When I set out to develop Hudson Woods, I was eager to find a project that I could lead, but knew that I couldn't do it alone. The site needed clearing and landscaping, the houses needed structure and materials, and the interiors needed to be furnished. To sell the homes, the whole project needed styling, photography, and marketing. This book is a resource manual for Hudson Woods in the most literal sense, because it contains information about many members of the dynamic team that brought it to life. But it's also a template for projects that haven't been developed yet—perhaps even yours—because it provides a roadmap for assembling a diverse group of talented people from the wide array of fields that architecture and real estate projects require.

The process of assembling the team for Hudson Woods alerted me to an unmet need in the real estate and design world. There was no one-stop shop that could provide access to a group of people as impressive as this one. So I set about creating that resource myself and launched Brick & Wonder, an online platform that connects real estate and design professionals with one another, and with clients, on a project-to-project basis.

This book represents just one example of what can be achieved when a group of builders and makers, from engineers and brokers, to photographers and designers, work together to bring a complex idea to life.

Welcome.



Drew Lang
Hudson Woods Architect & Developer





Partners



ALLEGHENY MOUNTAIN HARDWOOD



Allegheny Mountain Hardwood has been a family business for four generations. Situated in the heart of Northern Appalachian Hardwood Country forests since 1938, they have become known for the outstanding quality of their oak and cherry hardwoods.

Being family owned, using sustainable management methods, FSC certification, and utilizing all parts of the tree in production, AMH fits perfectly into the Hudson Woods vision, controlling the lumber from tree to finished board. The quality and history of the wood is reflected in the finished designs for each Hudson Woods home. Every room using AMH becomes a warmer, more inviting place.



SOURCE:

ALLEGHENY MOUNTAIN HARDWOOD
PO BOX 659 EMLINTON, PA 16373
#721-867-9441

CONTACT: JESSICA HICKMAN
JESSICA@HICKMANWOODS.COM

SPECIFICATIONS:

WOOD FLOORING: 4" WHITE OAK R&Q
NATURAL NB, 1'-7' LENGTHS

WOOD CEILING/WALL PANELING:
3" WHITE OAK R&Q NATURAL, NB

CARPORT INTERIOR WOOD PANELING:
3" MILLRUN ASPEN





ANDREW BECKER DESIGN

OWNER DESIGNER AND FABRICATOR, ANDREW BECKER

Andrew Becker is a long-time partner to Hudson Woods and LANG Studio, specializing in custom architectural metalwork that is innovative, modern, and functional.

As both an architect and a custom fabricator, Andrew's holistic design & build approach incorporates timeless hand-crafted detailing with the precision of digital technologies. This blend yields an authentic aesthetic, rich with unique detail and quality craftsmanship.

Every element is important, no matter how small. This philosophy is echoed throughout the Hudson Woods development and reflects the lived-experience within the Hudson Woods homes.



Pictured above, a custom steel mirror and concealed shelving brackets used in Hudson Woods master bath.



Pictured above is the custom railing system used at Hudson Woods.

SOURCE:

ANDREW BECKER DESIGN, LLC
STL/NYC/BKLYN/HUDSON VALLEY
#417-343-8279
ABECKER@ANDREWBECKERDESIGN.COM
WWW.ANDREWBECKERDESIGN.COM

SPECIFICATIONS:

- EXTERIOR DECK RAILINGS & STAINLESS CABLE SYSTEMS
- CUSTOM BLACK-OXIDE INTERIOR STEEL RAILINGS & BALUSTERS
- CUSTOM BLUE-OXIDE POWDER ROOM VANITY SHELF
- CUSTOM MASTER BATHROOM MIRROR
- CUSTOM SHELVING BRACKETS FOR KITCHEN, MASTER BATH & ENTRY BENCH



*“Connecting Place, Purpose
and Experience.”*





SAMUEL MOYER

OWNER AND DESIGNER, SAMUEL MOYER

At Samuel Moyer Furniture, a vital element of the design process is to develop a unique relationship with each built item. When the Hudson Woods team and Sam came together there was an immediate kinship through a shared affinity for natural living.

Many of the Hudson Woods homeowners chose to include a kitchen pantry in their living space. The pantry is designed by LANG Studio, and built in collaboration with Samuel Moyer Furniture. From the elegant proportions of the bi-folding, slatted doors made with beautiful black walnut, to the richness of the interior soapstone countertop, the pantry is a wonderful example of a successful collaboration with a likeminded partner.

The unit is designed with attention to detail and a love of sustainable materials. It is built with the practicality of the past and with ethics for the future. Samuel Moyer Furniture is committed to the idea of making furniture for our great grandchildren, a principle that is perfectly aligned with the vision of Hudson Woods.



The piece is designed to nestle into the great room as an extension of the kitchen. It has built-in electrical outlets, storage for small appliances and three drawer sizes to accommodate various needs. The drawers use custom cut box joints and are precisely set for smoother sliding, better durability, and greater longevity.

SOURCE:

SAMUEL MOYER
2092 ROUTE 9G
STRAATSBURG, NY 12580
#213-290-3824

SPECIFICATIONS:

KITCHEN PANTRY: SOLID BLACK WALNUT,
SOAPSTONE COUNTER, CUSTOM IN-LAID
BRASS DETAILS AND LEATHER DOOR PULLS,
INTEGRATED ELECTRICAL OUTLETS,
STORAGE FOR SMALL APPLIANCES



DZIERLENGA F+U

OWNER AND DESIGNER, CASEY DZIERLENGA

Dzierlenga F+U is a woodworking and design studio in the Hudson Valley operated by our friend Casey Dzierlenga. Her fun-loving approach to design and her strong connection to the Hudson Valley come across in each piece of furniture she builds. Her practice favors traditional hand-tooling techniques, so that each furniture piece is unique and bares the marks of a truly hand-crafted object.

Casey often uses reclaimed materials in her designs, such as wood from fallen trees, and she always sources locally in the Hudson Valley. We were drawn to her whimsical designs and installed some of them in the model house. We used her live-edge Vroom Lunascape coffee table in the downstairs den. In the kid's room we incorporated one of her playful rocking chairs.



Pictured above: The Lorca Coffee Table by Dzierlenga F+U

SOURCE:

DZIERLENGA F+U
1018 HOLLOW ROAD
SALT POINT, NY 12578
CONTACT: CASEY DZIERLENGA
DEVILLEDEGG@DZIERLENGA.COM

SPECIFICATIONS:

LIVE-EDGE VROOM LUNASCAPE
COFFEE TABLE

ROCKING CHAIR



WITTUS STOVES

Authentic and sincere design often stems from tradition, heritage and craftsmanship. After perfecting these elements for over 40 years, Niels Wittus and his company – Wittus Fire By Design – have been able to integrate timeless quality with evolving technologies to make beautiful, yet environmentally sustainable wood burning stoves.

Beautiful as an object and yet incorporating award-winning technology, the Wittus stove was the perfect choice for Hudson Woods. Wittus-Fire by Design is a Westchester business located in Pound Ridge, NY.



Pictured above, the Shaker stove in action within the model house great-room.

SOURCE:

WITTUS
40 WESTCHESTER AVENUE,
POUND RIDGE NY 10576
#914-764-5679
CONTACT: NIELS WITTUS
INFO@WITTUS.COM

SPECIFICATIONS:

THE SHAKER SHORT BENCH STOVE:
BLACK STEEL
OPTIMAL HEAT OUTPUT - 20,000 BTU 6KW
HEAT OUTPUT RANGE: 10-23KBTU 3-7KW
FLUE SIZE-6"
EFFICIENCY-78%







ECOSUPPLY



ECO Supply distributes green materials for commercial and residential projects in the United States. The company exclusively represents a great many European suppliers and is a pioneer in helping to introduce these green building systems and standards into our common design and building vocabulary.

The company has its roots in a small fabrication and custom furniture shop. Growing frustrated with a lack of green materials on the market, they began to offer a selection of green building products, a space which seemed like a void in the market. Today they have grown into a major force within the building material supply field.

At Hudson Woods it was important to provide a high quality wood window system that measured up to the strict European insulation standards. We decided to work with EcoSupply and Bildau & Bussman as our preferred Hudson Woods window supplier.



Near completion, the uninterrupted window wall in the great room of the model house at Hudson Woods.

SOURCE:

ECOSUPPLY
2115 WESTMORELAND STREET,
RICHMOND, VA 23230
#718-218-6737
CONTACT: BROOKS PERLIN
BROOKS@ECOSUPPLYCENTER.COM

SPECIFICATIONS:

BILDAU & BUSSMAN DOUBLE-GLAZED
WOOD WINDOWS





FISHER & PAYKEL



Fisher & Paykel is a New Zealand based company that has been designing award-winning home appliances since 1934. Now an international company with operations in 50 different countries, the quality of their products has made Fisher & Paykel a household name. We brought them in as partners at Hudson Woods because of their similarly human-centric approach to design and their commitment to sustainable environmental practice.

At Hudson Woods we worked closely with Fisher & Paykel to achieve a seamless integration of the kitchen appliances into the overall interior aesthetic.

Using the appliances' panel-ready covers we blended key units with the white oak paneling used throughout the homes, emphasizing a subtle but sophisticated interplay between craft and modern materiality.



A view of our Hudson Woods kitchen with custom paneled appliances.

SOURCE:

FISHER & PAYKEL APPLIANCES
ARCHITECTS & DESIGNERS BUILDING
150 EAST 58TH STREET, 3RD FL, SUITE 361
NEW YORK, NY 10155
#888-979-4535

SPECIFICATIONS:

- 30" SINGLE SELF-CLEAN BUILT-IN OVEN
OB30SDEPX3
- 30" GAS ON STEEL COOKTOP CG305DLPX1
- 36" REFRIGERATOR INTEGRATED FRENCH DOOR
PANEL READY RS36A80J1
- 24" DOUBLE DISHDRAWER DISHWASHER TALL
DD25DDFTX7
- 30" VENTILATION HOOD HC30DTX1





SUN VALLEY BRONZE



We partnered with Brandino Brass, a hardware supplier in Birmingham, Alabama, who represents Sun Valley Bronze. Both companies have now been longtime partners with Hudson Woods, with a product that perfectly meets our desire for a handcrafted yet modern touch.

Every door handle is made of sand cast solid bronze using traditional artisan techniques. All hardware is made to order and assembled by hand in the foundry and studio at Sun Valley Bronze, a family owned and operated business of over 21 years.

The attention to detail has truly made a difference. Almost everyone comments on the door handles when they visit the home! This hardware experience is a fundamental element of the design. It will yield gracefully to many lifetimes of use while remaining manifest through every swing of the door.



Pictured above is Sun Valley Bronze's Tube Lever - in the W2, Medium Pewter finish.

SOURCE:

SUN VALLEY BRONZE C/O
BRANDINO BRASS
2824 CENTRAL AVE. #100
HOMWOOD, AL 35209
#205-978-8900

SPECIFICATIONS:

DOOR HARDWARE:
HANDLE TYPE: TUBE LEVER
MODEL NO: L-112
FINISH: W2 MEDIUM PEWTER

CABINET HARDWARE:
TYPE: EDGE PULL
MODEL NO: CK-501
FINISH: W2 MEDIUM PEWTER

HINGES:
MODEL NO: 125BB- 4.5" X 4.5"
FINISH: US 10B







FERN

FURNITURE DESIGNER, JASON ROSKEY

FERN strives to create contemporary yet timeless furniture using sustainable practices. The studio was originally founded in 2009 in Brooklyn, NY by Jason Roskey and Maggie Goudsmit. Two years later, they moved to the Hudson Valley, a burgeoning source of outstanding contemporary design drawing from the wellspring of the region's longstanding furniture tradition.

Perfectly at ease within the Hudson Woods design, several FERN pieces were chosen to furnish our model home. These include The Sawyer Club Chair and The Spring Credenza, both found in the Hudson Woods den, and the Swell Stool in the master bathroom (left) and the guest bedroom.



FERN's Spring Credenza pictured above within the model house Den.

SOURCE:

FERN
243 WARREN STREET
HUDSON, NY 12534
#718-753-6032
CONTACT: JASON ROSKEY
INFO@FERNNYC.COM

SPECIFICATIONS:

THE SPRING CREDENZA
THE SAWYER CLUB CHAIR
SWELL STOOL





MICHAEL ROBBINS

FURNITURE DESIGNER, MICHAEL ROBBINS

Having studied photography at art school, it's easy to see how Michael Robbins' refined point of view translates into woodworking & furniture making. Every element of Michael's work has a simple but meticulously crafted sensibility.

Michael Robbins founded his eponymous studio in 2011 and designs and produces furniture in a former wool factory in New York's Hudson Valley. Drawing from simplicity, utility and a joy of form, Robbins creates pieces that are exceptionally well made using time-honored materials. A 7th generation native of Upstate New York, his furniture is carefully designed to reflect the simple beauty of his rural landscape. Two of Michael's pieces, showcased at Hudson Woods, embody many of the features of the Hudson Valley lifestyle.

Michael is largely self-taught, an idea he embraces for the freedom it gives him to experiment. He is interested in the relationships his forms have with one another, slowly creating an environment of pieces that are both rustic and modern, while maintaining the comfort and quality of everyday life. The furniture is hand-built by a small group of people in a building rich with manufacturing history. Through this process, Michael connects to the spirit of the craftspeople before him, designing quality wooden furniture for today.



Pictured above on the left, the Big Bend chair can be found in the great room at Hudson Woods. On the right, the Wickson chair fits perfectly in the bedroom nook.

SOURCE:

MICHAEL ROBBINS
212 MAIN STREET
GERMANTOWN, NY 12526
#315-761-8010

SPECIFICATIONS:

BIG BEND CHAIR
WICKSON CHAIR



WORKSTEAD



Workstead is a design studio based in New York City, internationally recognized for its work in hotels, restaurants, residences, and lighting & furniture design. Founded in 2009 by Stefanie Brechbuehler, Ryan Mahoney, and Robert Highsmith, the studio is sought after for its award-winning attention to detail and meticulous approach to the balance of beauty & necessity in its work.

With longevity as its foundation, the work of the studio has included such iconic hotels as The Dewberry, Rivertown Lodge, and the Wythe Hotel. Workstead's projects and products have been featured in Architectural Digest, the New York Times, T Magazine, Wallpaper, and recognized by Hospitality Design, Interior Design Magazine, and NYCxDDesign through numerous awards.

At Hudson Woods, one of the first statements in the home is made with the Industrial Chandelier that hangs over the stair hall, achieving both an impactful design moment and a warm, welcoming glow. In the carport we selected their adjustable wall lamp, for its playfulness mixed with a refined industrial aesthetic.



Pictured above is the Chandelier by Workstead that hangs within the Hudson Woods stairhall.

SOURCE:

WORKSTEAD
232 THIRD STREET, E102
BROOKLYN, NY 11215
#347-618-6096

SPECIFICATIONS:

INDUSTRIAL CHANDELIER - FINISH, BLACK
POWDER-COATED AND CAST BRASS

ADJUSTABLE WALL LAMP - FINISH, BLACK
POWDER-COATED CAST BRASS



ALLIED MAKER

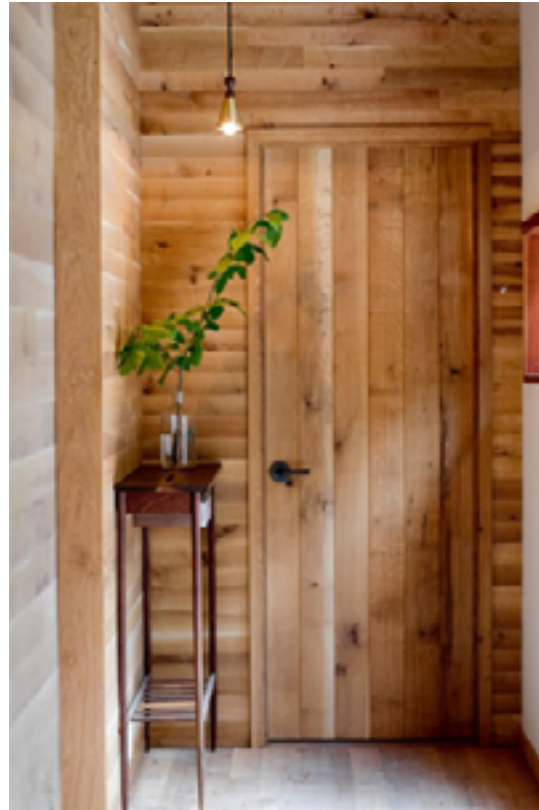

Located in Glen Cove, NY, Allied Maker is a contemporary lighting design studio founded by Ryden Rizzo. Although it started as an artful woodworking practice, it has organically evolved into a multi-disciplinary studio which collaborates with local artisans and manufacturers; as well as handcrafting and assembling products in-house.

Their approach to design stems from an obsession with raw materials. From the way a material sounds to its tactile properties to the aesthetic qualities of the finished product, every detail is important and contributes to the beauty of the piece. With Allied Maker's unique infusion of geometric simplicity, serious craftsmanship, and high-quality materials we felt an immediate kinship to the sensibilities of Hudson Woods. Allied Maker's focus on working with local partners further sparked our collaborative relationship.

The model house features four light fixtures from Allied Maker, each custom made to order. Pictured at left is the brass and oak Bell Pendant, hanging in the Entry Hall of the house. Referencing a classic hand bell, this petite and minimalist pendant houses rich textures of solid brass, white oak, and cotton cord.

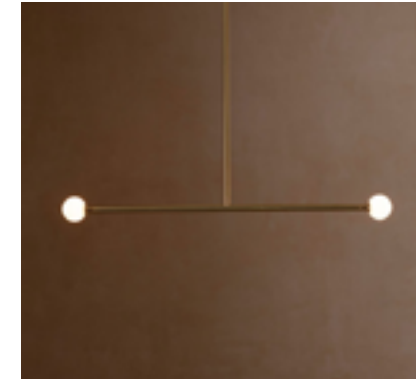

Top from left to right: Brass T2, A-Framed Half Moon, Dome Pendant 10", Bell Pendant.

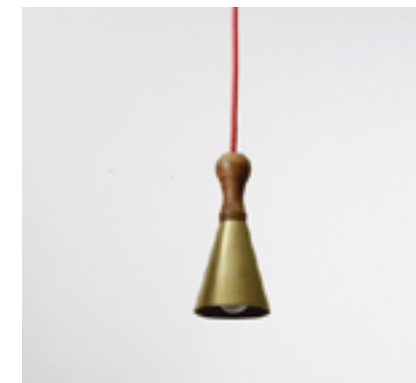

SOURCE:

ALLIED MAKER
81 FRANKLIN ST, NEW YORK, NY 10013
#212-334-7333
CONTACT: RYDEN RIZZO

SPECIFICATIONS:

BRASS T2 - FINISH, BRASS
A-FRAMED HALF-MOON - FINISH, BLACKENED
BRASS AND NATURAL BRASS
DOME PENDANT 10" - FINISH, BRASS AND
BLACK WALNUT
THE BELL PENDANT - FINISH, BRASS AND OAK



“Straight to the Source”

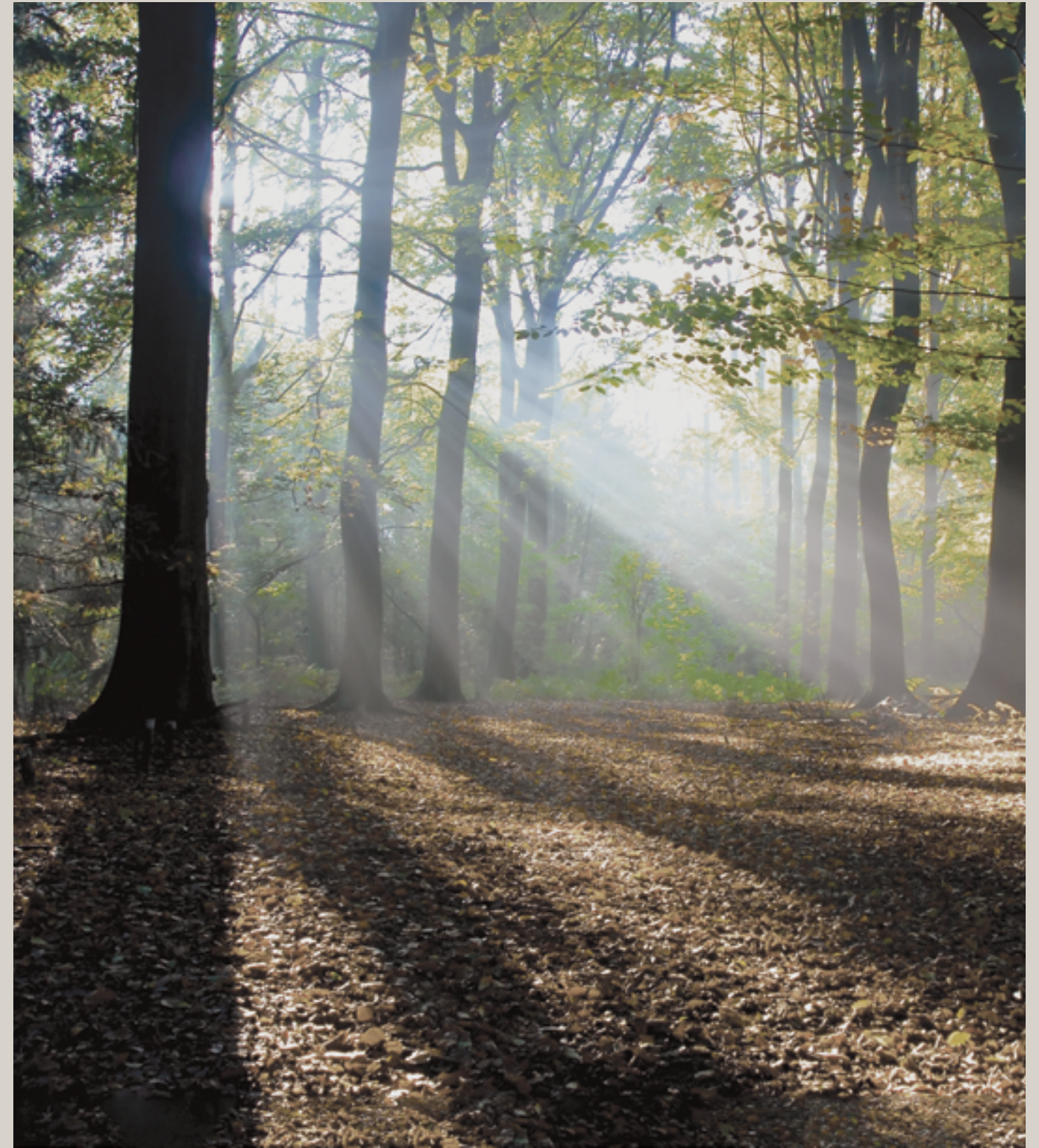



TRUEFORM CONCRETE

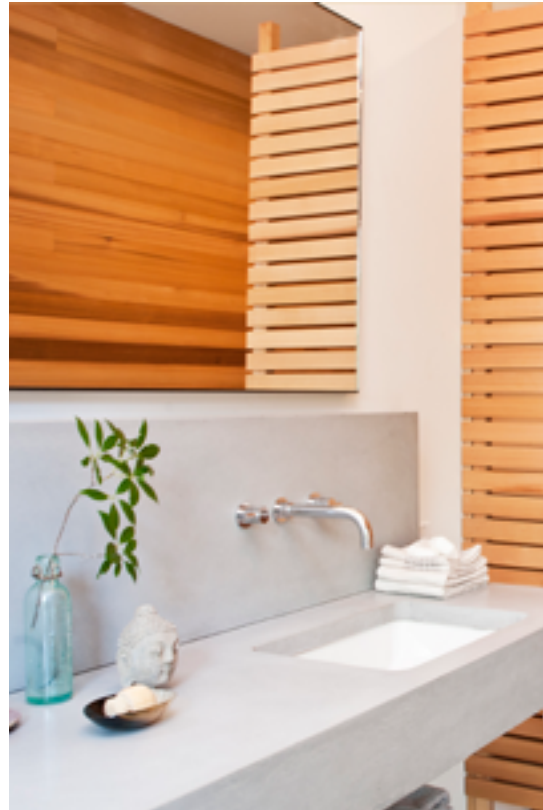

To achieve the consistency and simple beauty of the monolithic concrete vanity in the master bathroom, we turned to Trueform Concrete, a custom concrete fabricator based in New Jersey.

Durable, tactile and uniform, concrete provides the perfect foil for the natural materials that lend detail and warmth to the bathrooms in the Hudson Woods home.

Trueform are both flexible and highly collaborative partners that hold themselves to exacting standards. They delivered an uncompromising finished product that our home-owners truly love.

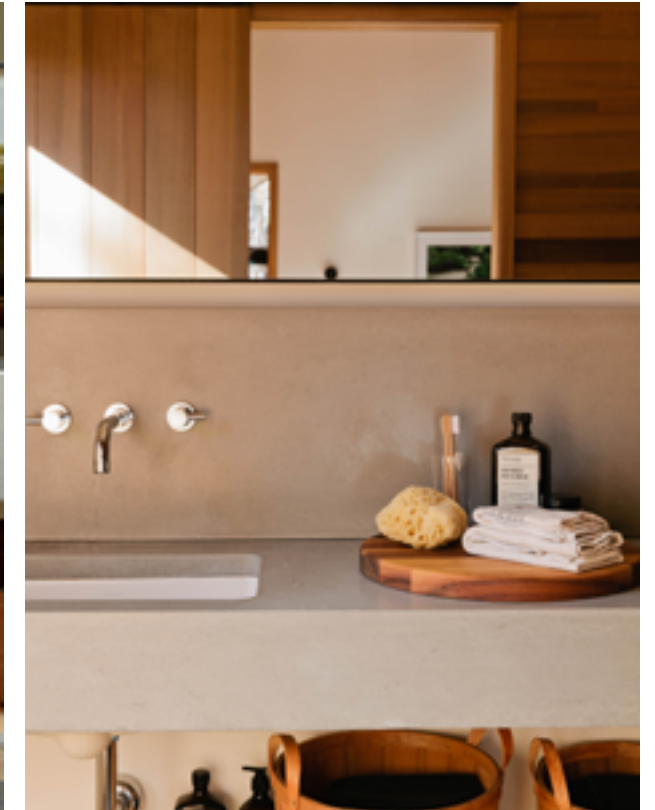

SOURCE:

TRUEFORM CONCRETE
321 RICHARD MINE RD #400
WHARTON, NJ 07885
#1-866-419-6321
CONTACT: PAUL GRECH

SPECIFICATIONS:

CUSTOM CAST CONCRETE VANITY



WALKER ZANGER



After more than 60 years of fine-tuning the art of tile-making, Walker Zanger mixes and marries patterns, materials and colors with a modern sophistication that transcends style by relying on traditional craftsmanship techniques.

Sharing in the design values and sensibilities of Hudson Woods, their inspiration comes from nature, art and fashion. They have developed special relationships with prized marble and stone quarries throughout the world. Each piece is individually selected and evaluated by experienced stone masters.

A material we are particularly fond of at Hudson Woods is the grey quartzite tile which provides a subtle but rich texture for a large, open bathroom layout. Tactile and earthy, its unique nature and rough-hewn surface make it a perfect companion to other elemental materials like wood, glass and metal. By contrast, we elected to use the pure white Soho ceramic tiles in the second bathroom. A nod to New York tradition and heritage, the clean and crisp design creates a light and airy atmosphere.



Pictured above is the grey quartzite tile, installed from floor to ceiling in the master bathroom shower.

SOURCE:

WALKER ZANGER
37 EAST 20TH ST
NEW YORK, NY 10003
#212-844-3000
CONTACT: WALKER ZANGER

SPECIFICATIONS:

GREY QUARTZITE STONE TILE

PURE WHITE SOHO CERAMIC
SUBWAY TILE





M. TEXEIRA SOAPSTONE



Rogério began M. Teixeira Soapstone on his own in the late 90's, importing and selling stone materials at local markets. From these first small amounts to 400lb boulders being delivered to his father-in-law's garage, Rogério's business grew to serve building grade material sizes. All the stone he sells now is still sourced from the area of Brazil where Rogério grew up.

The soapstone counters of Hudson Woods bring heritage from another part of the globe into the homes - an exotic, yet warm and familiar touch.

Brazilian Soapstone is mainly quarried in the state of Minas Gerais, near the towns of Ouro Preto and Mariana. This area is approximately 300 miles northwest of Rio. This area of Brazil has a lot of history and is home to a rich Baroque architectural influence. Ouro Preto itself is listed as a UNESCO Heritage Centre. Here, soapstone can be found everywhere in churches, house facades and especially in the cookware used by locals.



One of the home upgrades we offer is the kitchen island; shown above with an oiled Mariana soapstone slab from M. Teixeira Soapstone.

SOURCE:

M. TEXEIRA SOAPSTONE
547 S BROAD ST, GLEN ROCK, NJ 07452
#201-444-0778
CONTACT: ROGER TEIXEIRA
RMT@SOAPSTONES.COM

SPECIFICATIONS:

ANASTACIA SOAPSTONE SLAB - 1-1/2" SLAB
(KITCHEN ISLAND)

ANASTACIA SOAPSTONE SLAB - 3/4" SLAB
(PANTRY COUNTERTOP)
FINISH - HONED AND OILED



“Where Design Meets Nature.”





HEATH CERAMICS

Located in Sausalito, California, Heath Ceramics has been making objects for the home since 1959. Knowing the rich tradition and heritage behind their work, we reached out to outfit the Hudson Woods kitchens with a selection of Heath Ceramics tiles.

Hudson Woods buyers were offered a selection of tile colors for their custom kitchen backsplash. Since the Hudson Woods design makes the kitchen a central focal point within the expansive great room, the materials selected had to be truly special.

What began as a small-scale pottery shop in 1948, with Edith & Brian Heath, has evolved into a crew of 40 skilled craftsmen (many having worked there for 20+ years) making products by hand and on location, often using methods and techniques developed by Edith throughout her life. The high-quality, artisanal nature of Heath Ceramics is balanced with a simple and modern aesthetic which fits perfectly with our vision at Hudson Woods.



Staying true to the Heath tradition, every tile is hand cut and hand glazed, giving each piece unique depth and variation. Pictured above is the model house kitchen backsplash, using the Classic Field Tile in Jade Manganese color.

SOURCE:

HEATH CERAMICS
CONTACT: CATHERINE BAILEY
WWW.HEATHCERAMICS.COM

SPECIFICATIONS:

CLASSIC FIELD TILE, 3"X6"
COLORS OFFERED: JADE MANGANESE,
JADE PORCELAIN, CAMPARI RED,
POMEGRANATE, MID CENTURY WHITE,
NEW OPAQUE WHITE





CARL HANSEN & SØN

As a partner, Carl Hansen & Søn have the same founding tenets as Hudson Woods. Their products are designed intelligently, and executed with skill and precision. The wood is from sustainably managed forests and is treated in a way that is as gentle as possible for the environment. Sustainability is just as critical for Carl Hansen & Søn as it is for the Hudson Woods design team.

With years of Danish heritage and tradition, Carl Hansen & Søn is known for manufacturing many iconic furniture designs, several of which were created by Hans J. Wegner, including the Wishbone Chair, Elbow dining chair and Shell lounge chair.

For the model house, we selected a number of items including the Colonial Chair designed by Ole Wanscher in 1949. Another item we sourced from Carl Hansen & Søn is the Hans J. Wegner CH163 Sofa, designed in 1965. For the model house, we selected black leather, making this beautiful sofa a prominent feature when entering the great room of the model house.



Pictured above is Carl Hansen & Søn's Hans J Wegner CH163 sofa, a centerpiece of the great room at Hudson Woods.

SOURCE:

CARL HANSEN & SØN
251 PARK AVENUE S, 13TH FL
NEW YORK, NY 10010
#212-242-6736

SPECIFICATIONS:

THE COLONIAL CHAIR
THE CH163 SOFA, A HANS J. WEGNER
BLACK LEATHER





MODERNLINK



At Hudson Woods, we feel a certain kinship with Scandinavian design standards and values. The ideals always rely on user experience, craftsmanship, longevity and simple living. For these reasons we turned to Modernlink, a New York based shop of experts in vintage Danish furniture to find a few pieces for the model home that fit just right. Their young, talented designers and artisans pick the best of mid-century furniture, and restore it to its original pristine existence. Each piece that comes from Modernlink combines effortless modernity with contemporaneity. The selections at Modernlink always focus on being functional with attention to detail, comfort, lifestyle and simplicity.

We selected three items from the Bensen family of products including the Torii stool, Edward sofa and Frame Lo bed frame as well as several vintage Danish pieces. The Torii stools, standing at the kitchen island, bring a subtle character to the space with the arched backrest and distinct proportions. The name Torii comes from wood entrances to Japanese shrines which translates into English as "Bird Perch".

The sofa from Bensen helps bring a cozy and comfortable feeling to the downstairs den. The name references American mid-century designer Edward Wormley whose work has remained highly influential.



For the downstairs den of the model house, we selected this mid-century modern writing desk from Modernlink's collection.

SOURCE:

MODERNLINK
35 BOND ST, NEW YORK, NY 10012
#212-254-1300
CONTACT: WILLIAM LEE

SPECIFICATIONS:

BENSEN FAMILY: TORII STOOL, EDWARD SOFA AND THE LO BED FRAME



ERNEST NY



Ernest NY is a design collective created by D'apostrophe with three partners; Royal Botania, Renson and Delta Light, featuring the latest architectural and design products from Belgium & Europe. We partnered with Ernest NY to introduce high-quality, durable and design-minded outdoor furniture to the project.

Ernest NY strives to offer a collection of furniture that blends precision and functionality. Much aligned with the Hudson Woods emphasis on sustainability, the Royal Botania collection is made from carefully-selected, mature teakwood harvested in strict accordance with the sustainable forest policy promoted by WWF. Pictured at left we use their coated aluminum Alura armchairs poolside. We selected their teak Zenhit series lounge chairs and side table for the model house deck.



Providing a comfortable and stylish perch on the model house deck are the Zenhit series lounge chairs by Royal Botania.

SOURCE:

ERNEST NY
255 5TH AVENUE, 6TH FLOOR
NEW YORK, NY 10016
#212-334-5045

SPECIFICATIONS:

THE ZENHIT SERIES LOUNGE CHAIRS
THE ALURA WHITE ARMCHAIRS





“To create authentic, meaningful experiences at every turn”



WOCA DENMARK



Hardwood flooring is a natural product - it can dent, move and stain, but this character can add beauty over the years. In order to allow this character to emerge over time, there is some responsibility on the homeowner. We wanted a simple and effective treatment that would not alter the natural beauty of the wood. For this, we turned to our friends at WOCA Denmark for their advice in helping this material age gracefully over time.

We finished the white oak flooring with WOCA Penetrating Oil, a plant based, eco-friendly wood finish made in Denmark. Penetrating oil penetrates and fortifies the wood from the inside, whilst still allowing the wood to 'breathe'. WOCA Oil has been around for several decades, and has a long tradition of use in Scandinavian countries. Oiled floors need proper care to perform well and look good. Soaping floors is a European tradition that we've incorporated into Hudson Woods floor care. We use WOCA Natural Soap to clean the floor and condition the finish. The goal is to maintain and nourish the finish, not strip it.

One of the greatest benefits of a WOCA Oiled floor is that when it comes time to "refinish", sanding is not typically necessary, unlike a polyurethane finish. A coat of WOCA oil is simply applied to "refinish" the wood surface, making it truly a dustless refinish.



SOURCE:

WOCA DENMARK
TVAERVEJ 6
6640 LUNDERSKOV
DENMARK
#1-770-482-2259
INFO@WOCAWOODCARE.COM

SPECIFICATIONS:

WOCA DIAMOND PENETRATING OIL





CALICO WALLPAPER

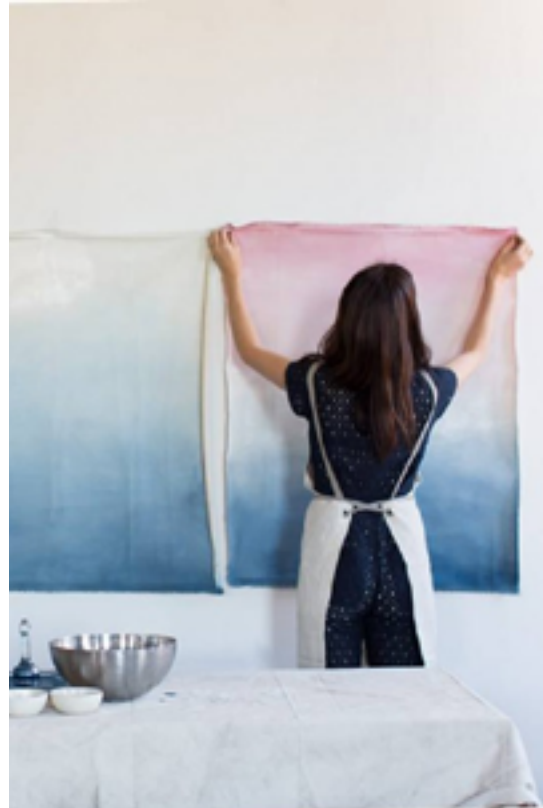

Our friends at Calico Wallpaper are well-known and highly regarded in the design community for their wallpaper styles, in the New York area and internationally. Founded by husband-wife team Nick and Rachel Cope, their method incorporate experimentation with the re-appropriation of traditional art forms and digital processes to create immersive environments.

As part of a creative collaboration with Hudson Woods, the Calico team created an installation at the model house inspired by the wooded landscape and clear blue skies of the area.

The panels they created are 100 percent linen, colored using ombré dip-dye techniques with fiber-reactive dyes and sea salt. The process evolved out of their discovery of Hudson Woods and the development of the finished triptych that hangs in the great room of our model house evolved over the course of the project.



Pictured above is the original installation by Calico, installed in our Model House.

SOURCE:

CALICO WALLPAPER
177 DWIGHT STREET SUITE 3R
BROOKLYN NY 11231
#718-243-1705

SPECIFICATIONS:

4'X4' LINEN PANELS CUSTOM DYED WITH
FIBER-REACTIVE DYES AND SEA SALT



CLOAK



Founded in 2014 by Samuel Ruckstuhl, Cloak is a carpet company dedicated to architects and interior designers.

With a family legacy of more than a hundred years of carpet weaving in Switzerland, Cloak uniquely combines this ancient craft of carpet making with a contemporary design approach.

The Lanura undyed virgin wool rug (pictured at left) provides a soft and streamlined foundation for the furniture in the great room. It is made from wool in its pure state, spun to yarn by hand and then woven by hand as well. Downstairs in the kid's room we opted for a pop of color, with Cloak's turquoise feltro rug, made from of pure new wool fibers.



Pictured above is the Feltro rug in turquoise.

SOURCE:

CLOAK GMBH
GRELLINGERSTRASSE 33
4052 BASEL, SWITZERLAND
WWW.CLOAK.CH

SPECIFICATIONS:

THE LANA UNDYED VIRGIN WOOL RUG - (HW GREAT ROOM)
THE AGAVE RUG - (HW DEN)
THE FELT RUG - (HW CHILDREN'S BEDROOM)



USM MODULAR FURNITURE



Founded in Switzerland in 1885 as a producer of iron works and window fittings, USM Modular Furniture evolved to start producing iconic furniture designs in 1961. Their USM Haller design is so highly-regarded by the art and design community that it has its' very own place as part of the Museum of Modern Art's permanent furniture collection.

The same piece can also be found at our Hudson Woods model home. We use it here (left) in the master bedroom as a dresser. In bright yellow it adds an instant pop of color and drama when set against the more natural materials found throughout the home.

The modular aspect of the design makes it a great fit for a variety of spaces and enables customization for specific needs. Key to USM's philosophy is ensuring a long lifespan for their products, using only high-quality, durable materials and manufacturing with the newest, environmentally friendly technologies. Ultimately, the longer the lifespan of a piece of furniture, the lower its environmental impact will be.

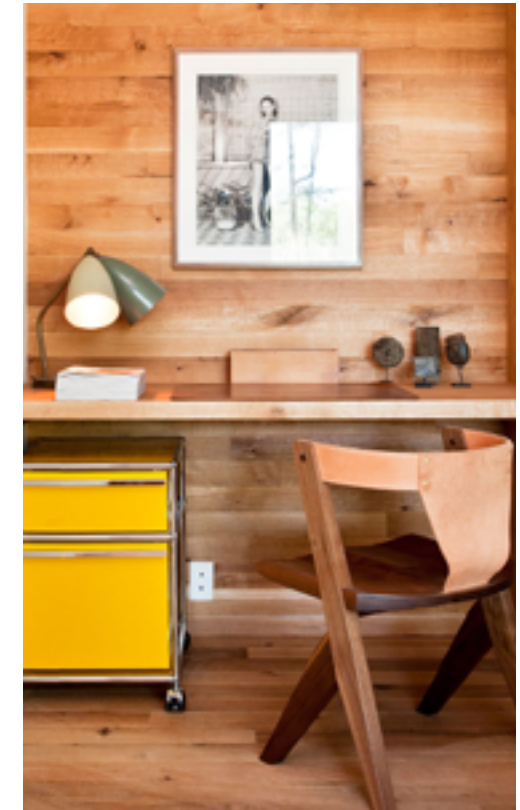

*Top left: The USM Haller credenza is used as a dresser in the Master Bedroom of the model house.
Top right: We also included this USM mobile pedestal, tucked within our desk nook downstairs.*

SOURCE:

USM MODULAR FURNITURE
28 GREENE STREET
NEW YORK, NY 10013
#212-371-1230
WWW.USM.COM

SPECIFICATIONS:

USM HALLER CREDENZA (YELLOW)
USM HALLER FILE PEDESTAL (YELLOW)

*“Integrity of the landscape
is privileged over ease of
construction”*

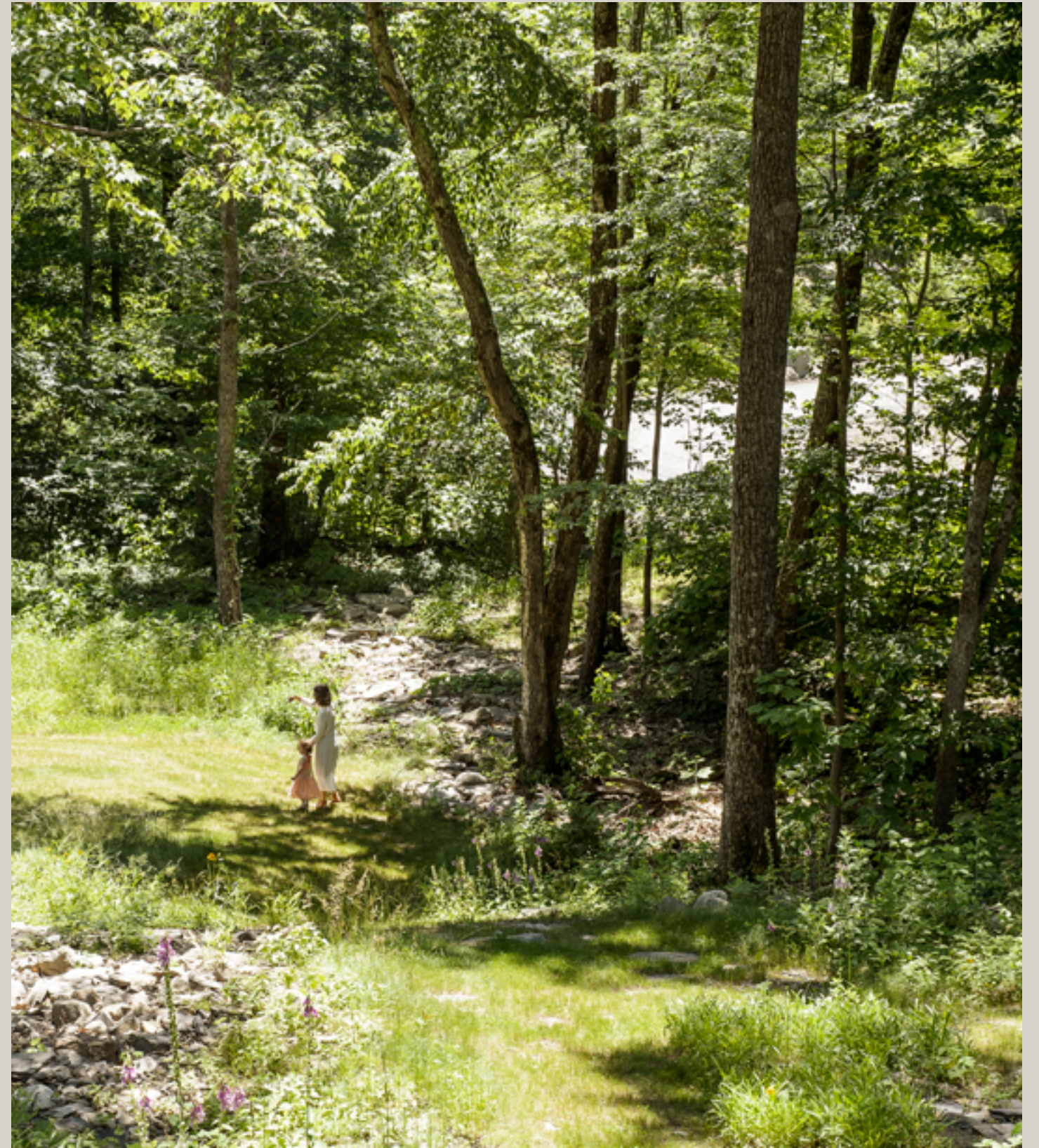



Earth Designs



Earth Designs, founded by Aja Hudson in 2001, began as a one-woman gardening business and has since evolved into a landscape & garden design company with over 25 employees. Earth Designs transitioned into an employee-owned cooperative in 2016, inspired by Aja's desire to create more sustainable jobs and support social & economic change.

The following mission statement of Earth Designs resonates strongly with our own core values, making them an ideal partner for this key aspect of the project.

“Our vision is to foster meaningful connections between people and plants through the creation of unique installations, woodland plantings, native meadows, and vegetable and medicinal gardens. Our work is infused with sustainable, eco-friendly and organic methods; we strive to care for every property and each plant with loving respect, maintaining the idea that creating a more sustainable planet rests in the hands of each of us doing our part.”

Because of these shared values, we turned to Aja for her ability to enhance the raw beauty of the Hudson valley landscape rather than attempt to modify it. Many of our homeowners have also turned to her for their landscaping needs with wonderfully natural results.



SOURCE:

EARTH DESIGNS
363 MAIN ST, ROSENDALE NY
#845-658-7077
CONTACT: AJA HUDSON
INFO@YOUREARTHDESIGNS.COM

SPECIFICATIONS:

SELECT INDIGENOUS PLANT MATERIAL



Building Assemblies





When conceptualizing the design for Hudson Woods, it was important for us to keep the architecture simple, thereby allowing the homes to nestle within their surroundings and allowing nature to be the dominant experience. This holds true from the very beginning of one's trajectory through the development. The gravel roadways follow the natural contours of the site, winding towards their destinations in a quiet, unobtrusive way.

The entrance to the Hudson Woods home is similarly quiet, bringing about a sense of peace and an appreciation for the surroundings rather than demanding a lot of attention. A boulder unearthed while excavating for the homes now serves as a stepping stone to the entrance platform. The natural cedar cladding brings about a sense of warmth and the small, shuttered windows, a sense of shelter and safety. Many of the formal details of the design were inspired by local vernacular buildings, such as farm structures.

Once inside it was important for us to create a more dramatic framed view of nature via the picture window, seen across the stair hall and adjacent to a comfortable area for cloaks and boots. The cedar paneling and white oak flooring are very primary throughout this experience.



Pictured above, we created a nook for coat and shoe storage beneath a dramatic live edge bench. Utilitarian in design, the gesture also creates a welcoming display as one's first stop in the house.

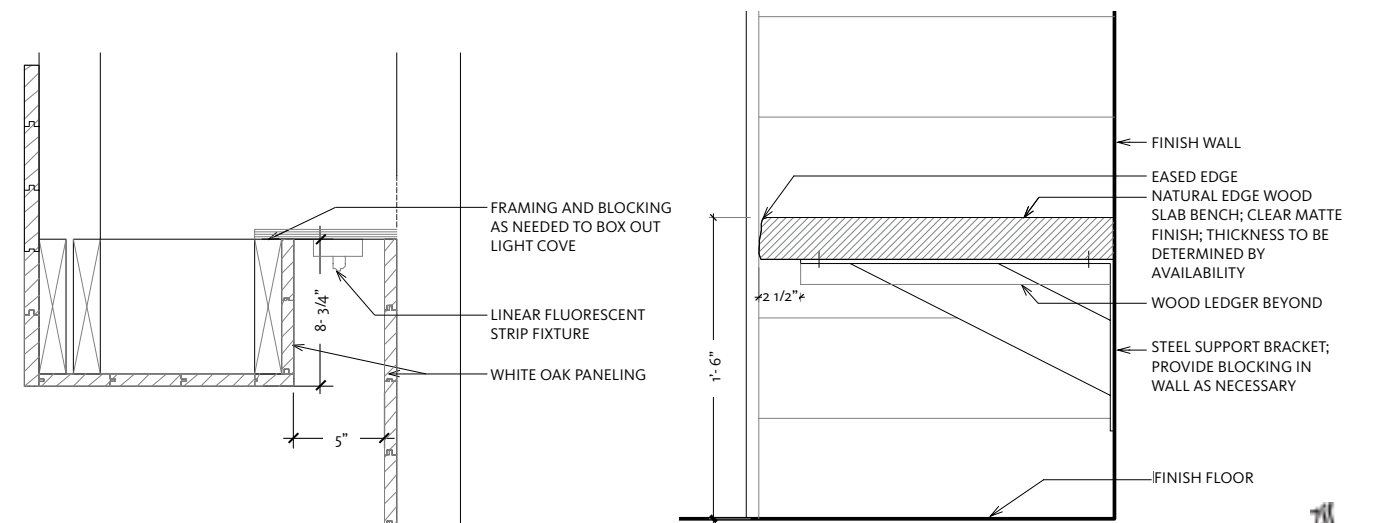
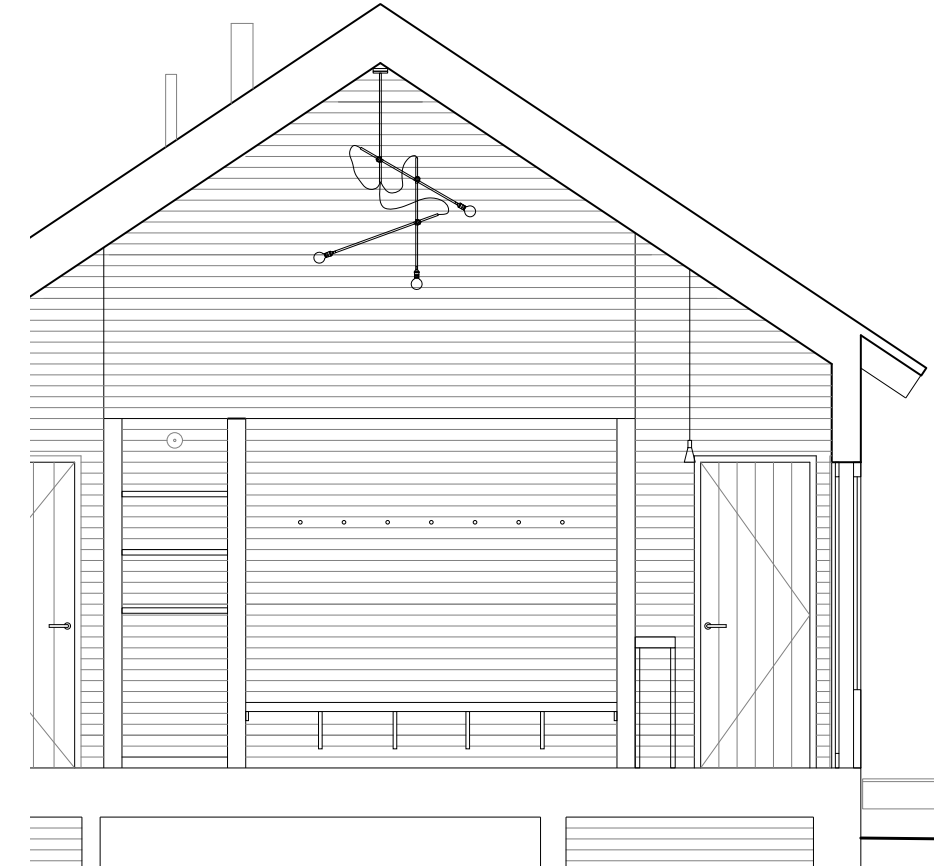

Upon entering the house, to one's left is the powder room upgrade. In the model house we've installed the Preying Mantis console by one of our frequent collaborators, Sam Moyer. Hanging above is the decorative brass and oak pendant from Allied Maker, providing a small point of light. Intentionally spare in its design, the architecture was intended to allow the individual homeowners to embellish and adapt these spaces to become their own.

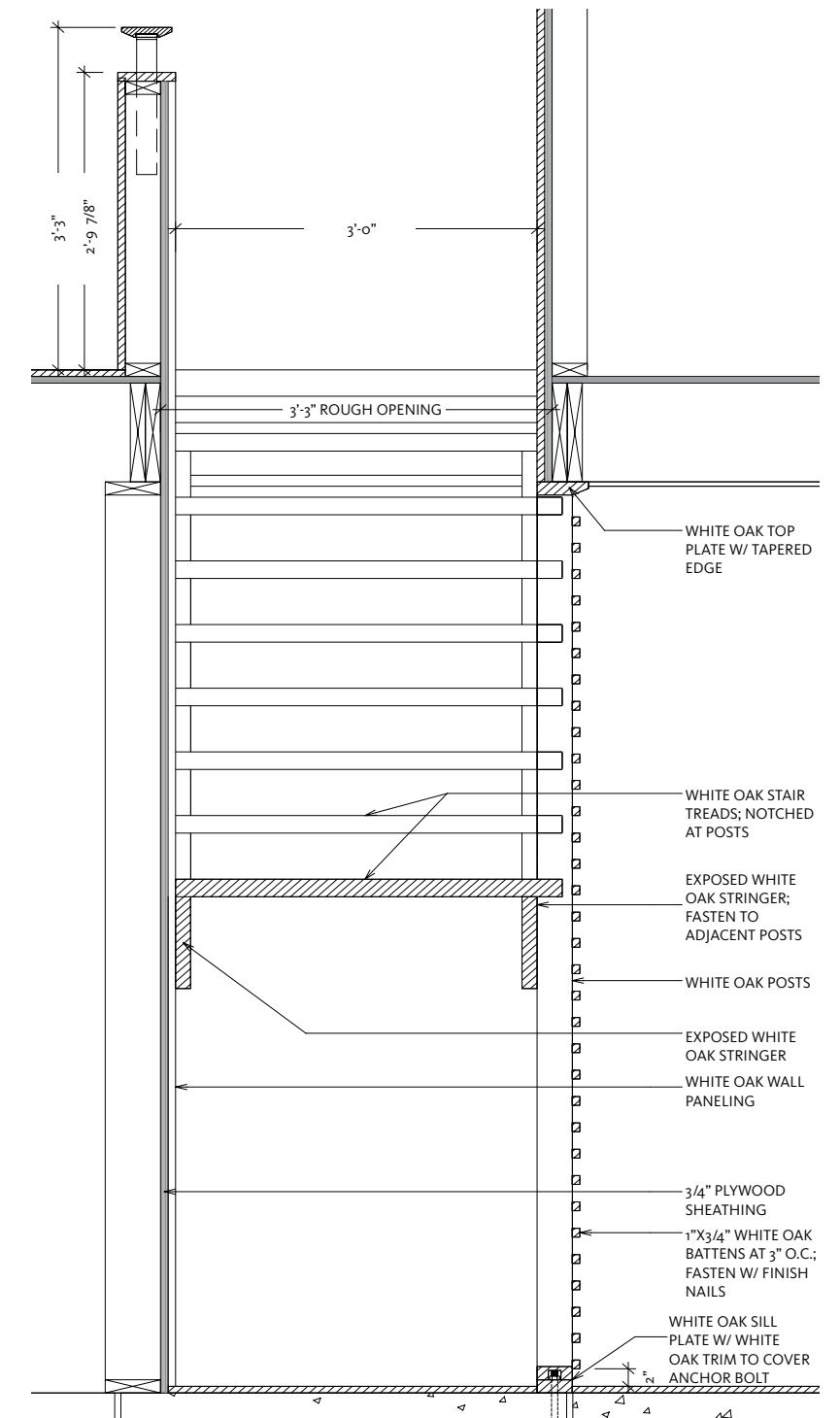
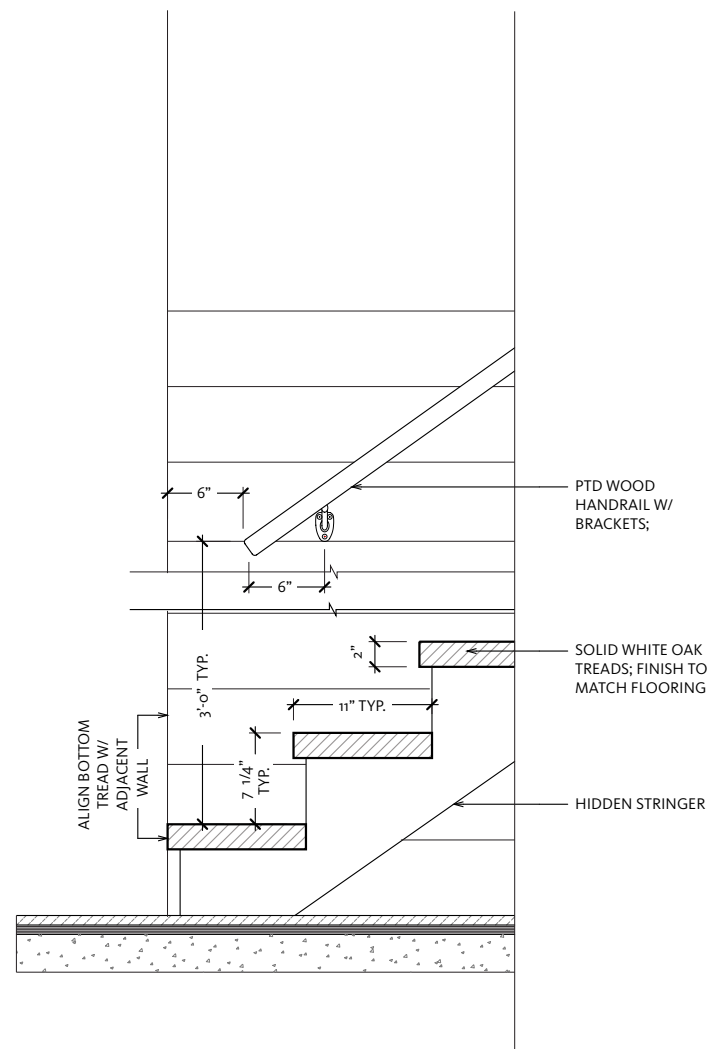



The kitchen, open to the great room and the dramatic gabled windows that Hudson Woods is known for, is central to the home. Rather than the distractions of urban life, the focus here is on togetherness and warmth. The cedar paneling in the entryway continues into this space, blending together with the custom kitchen cabinetry. For a pop of color, we selected subway tile from Heath Ceramics. The concrete countertop provides a durable and modern work surface. Floating shelves were installed overhead to allow for a curation of interesting objects on display. We sought these sorts of moments that would allow our buyers to inject themselves into the architecture.

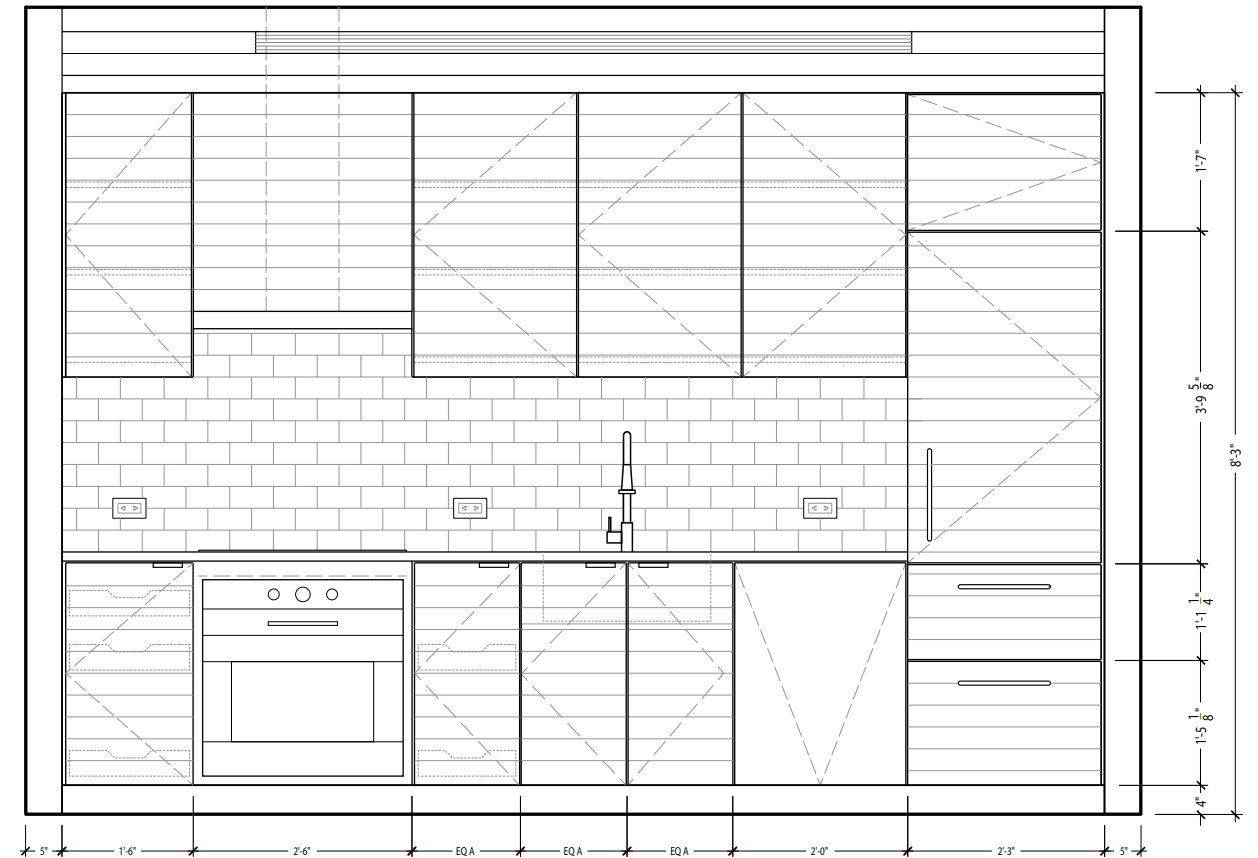

Pictured above is the Hudson Woods kitchen elevation and feature wall.

Pictured from left, kitchen accessories from Kauffmann Mercantile are displayed on floating shelves.

Pictured at right, the big picture window with a low sill-height serves to capture the outdoors and further bring nature into the home.

The large rectangular dining table, bench and dining chairs are from the Sawkille Company.

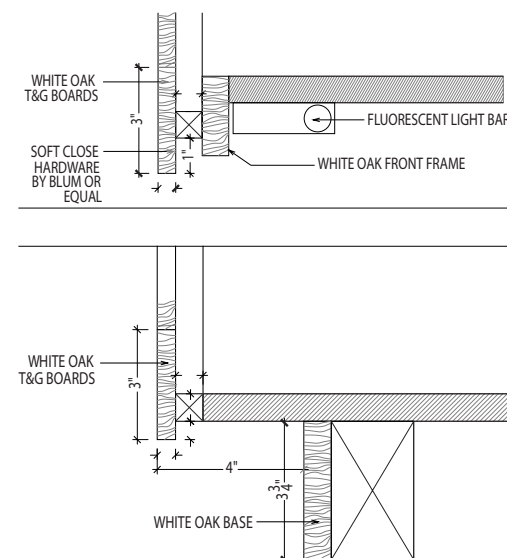
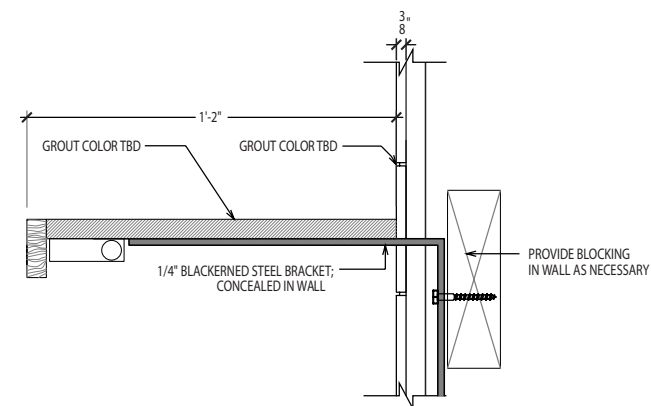
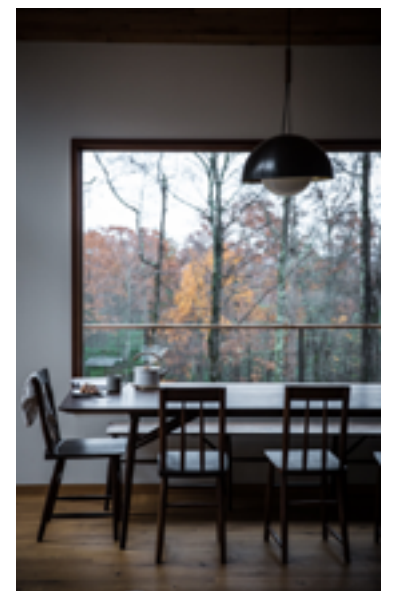

Another defining characteristic of this space is the furniture. Two special elements of the kitchen are the custom built kitchen pantry and the kitchen island. Both pieces were custom-designed by the Lang Studio team and built by Samuel Moyer. Sold as upgrades, we've found that a great many of our home-owners opted to include one or both pieces as they work so well together.

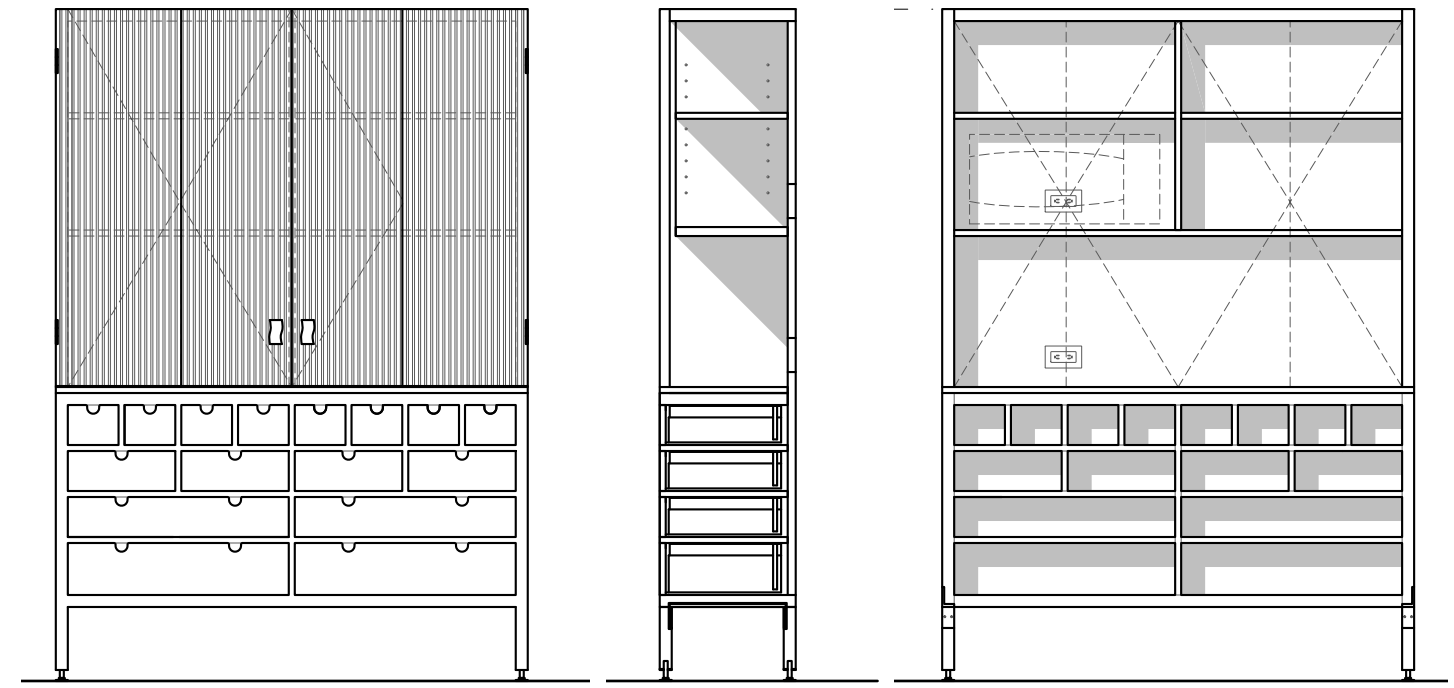

Pictured from left to right, a corner detail view of the pantry highlights the rich combination of materials together with hand-tooled craftsmanship.

On the right is a close view of the black walnut slatted doors and the supple leather pull hardware.

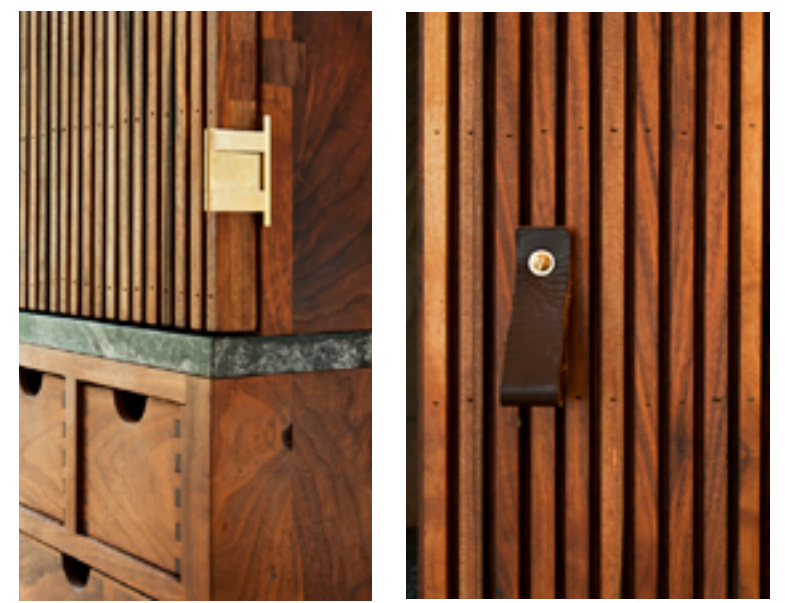



The kitchen island is composed of a blackened steel base frame with black walnut drawers with custom walnut drawer-inserts that provide ample added kitchen storage.

The large soapstone countertop and blackened steel create a pleasing contrast to the natural white oak tones of the room. The island provides a focal point and gathering place around one of the most enjoyable rooms in any house - the kitchen.

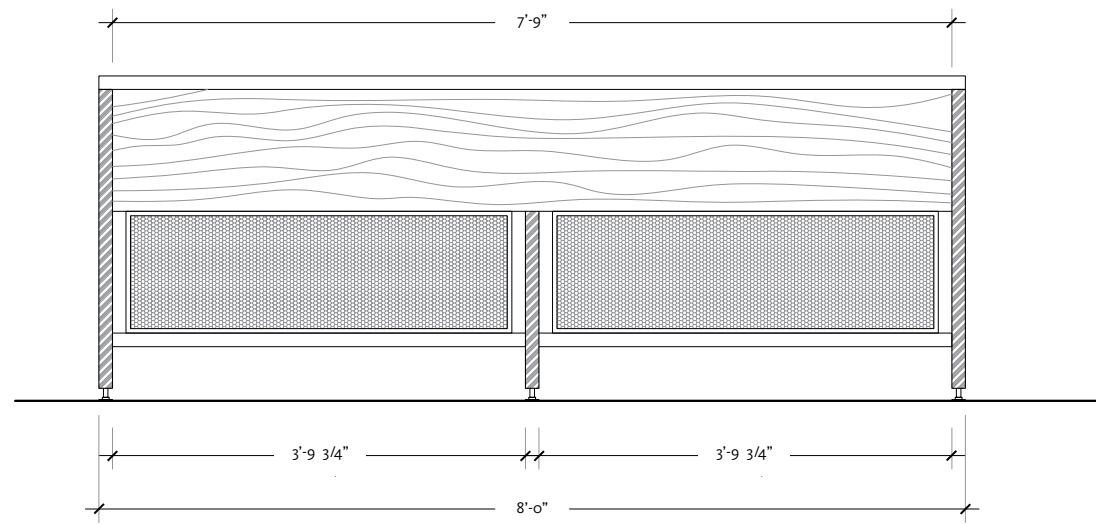
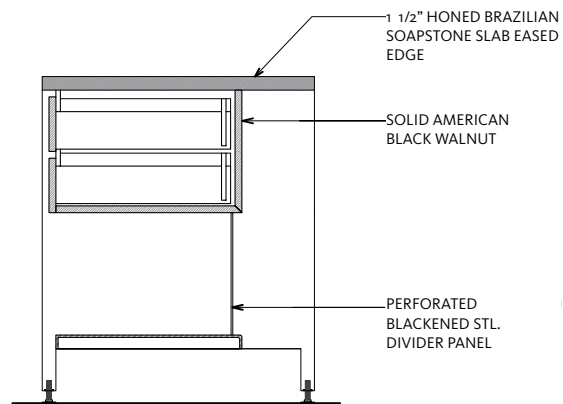

BACK ELEVATION

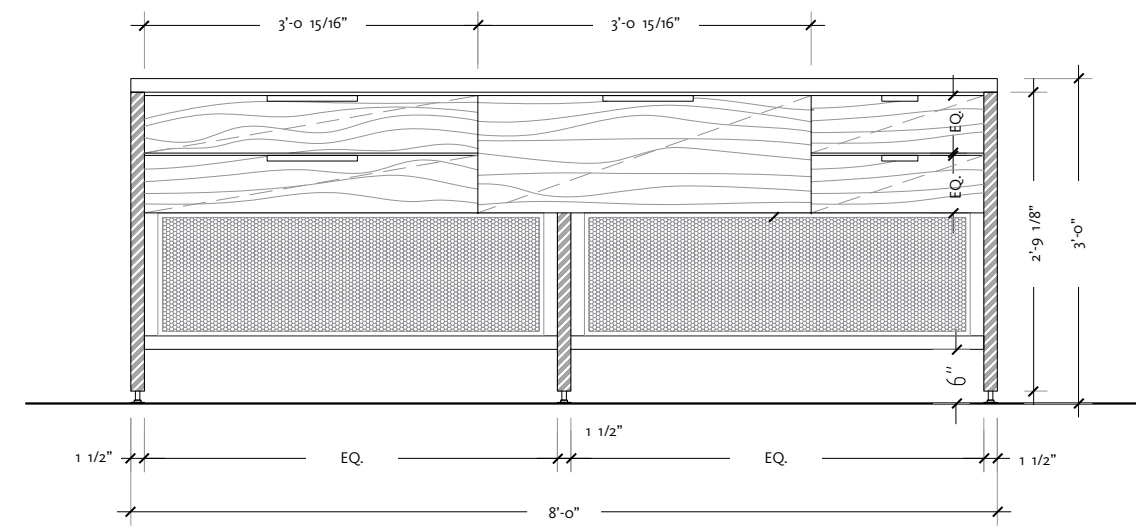

FRONT ELEVATION





The use of natural materials and a muted color palette continues into the master bathroom. We selected Oyster Grey natural cleft quartzite for the bathroom floor surface. To connect the room back to the rest of the house, the cedar continues into this space with the baseboard and cedar-paneled barn door. The shower walls are fully lined with the same oyster grey quartzite tile. For texture we used a smaller module of stacked quarry stone quartzite on the shower feature wall.

In many of our bathroom projects at Lang Studio, we opt for wall-hung sinks and toilets, for a more streamlined feel, and for purely practical reasons such as ease of cleaning. We applied the same reasoning here, and commissioned Trueform concrete to create a large, double-basin concrete sink. Custom brackets were fabricated by Andrew Becker Design, mounting the vanity to the wall without visible supports. We also provided a full-length cedar towel shelf beneath the vanity for additional storage space.



We used sliding barn door hardware from Rustica Hardware, for the entrance to the bathroom--seen here reflected above in the custom mirror fabricated by Andrew Becker Design.

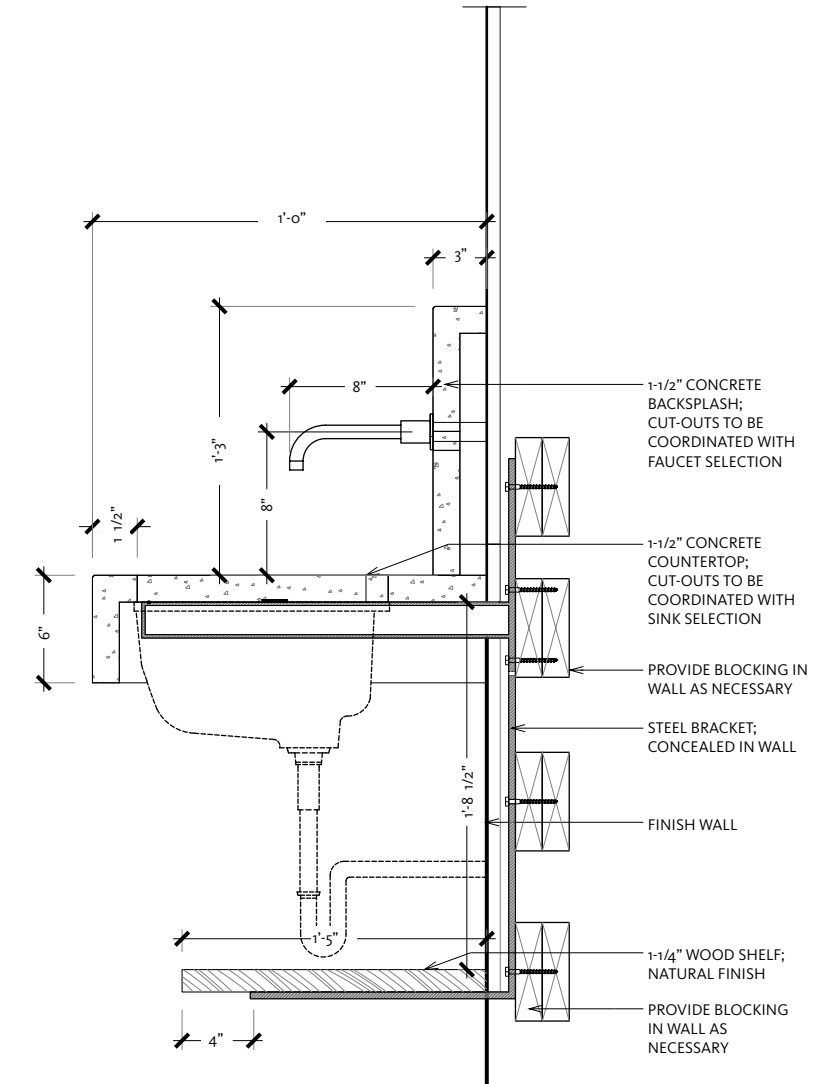

We continued the same materials into our outdoor bathing interventions. Pictured at far-right is a detailed view of our hot tub, and center-right, a cedar lined sauna attached to the pool house.

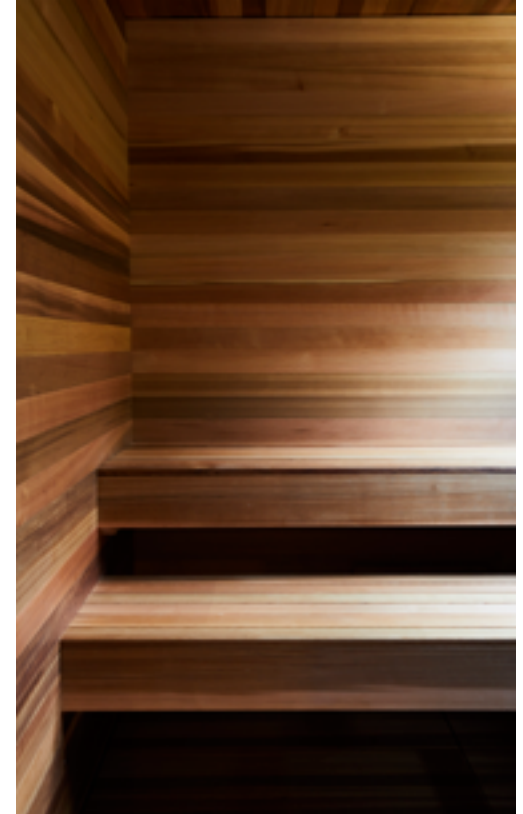
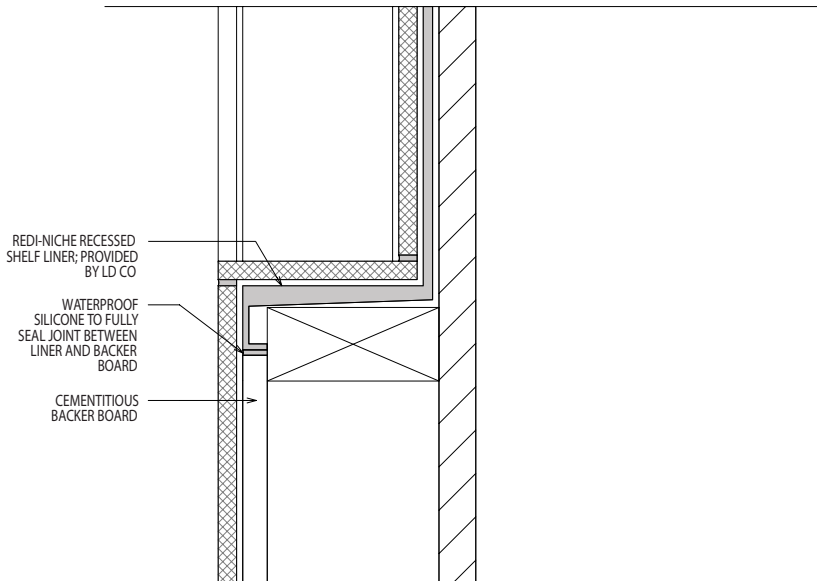
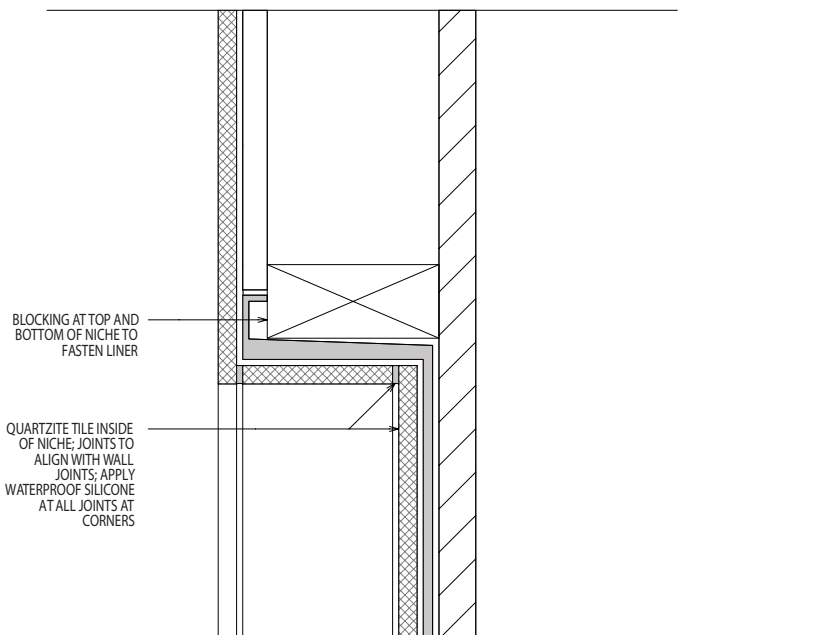

“Framing views of nature and allowing light to animate the space was key”

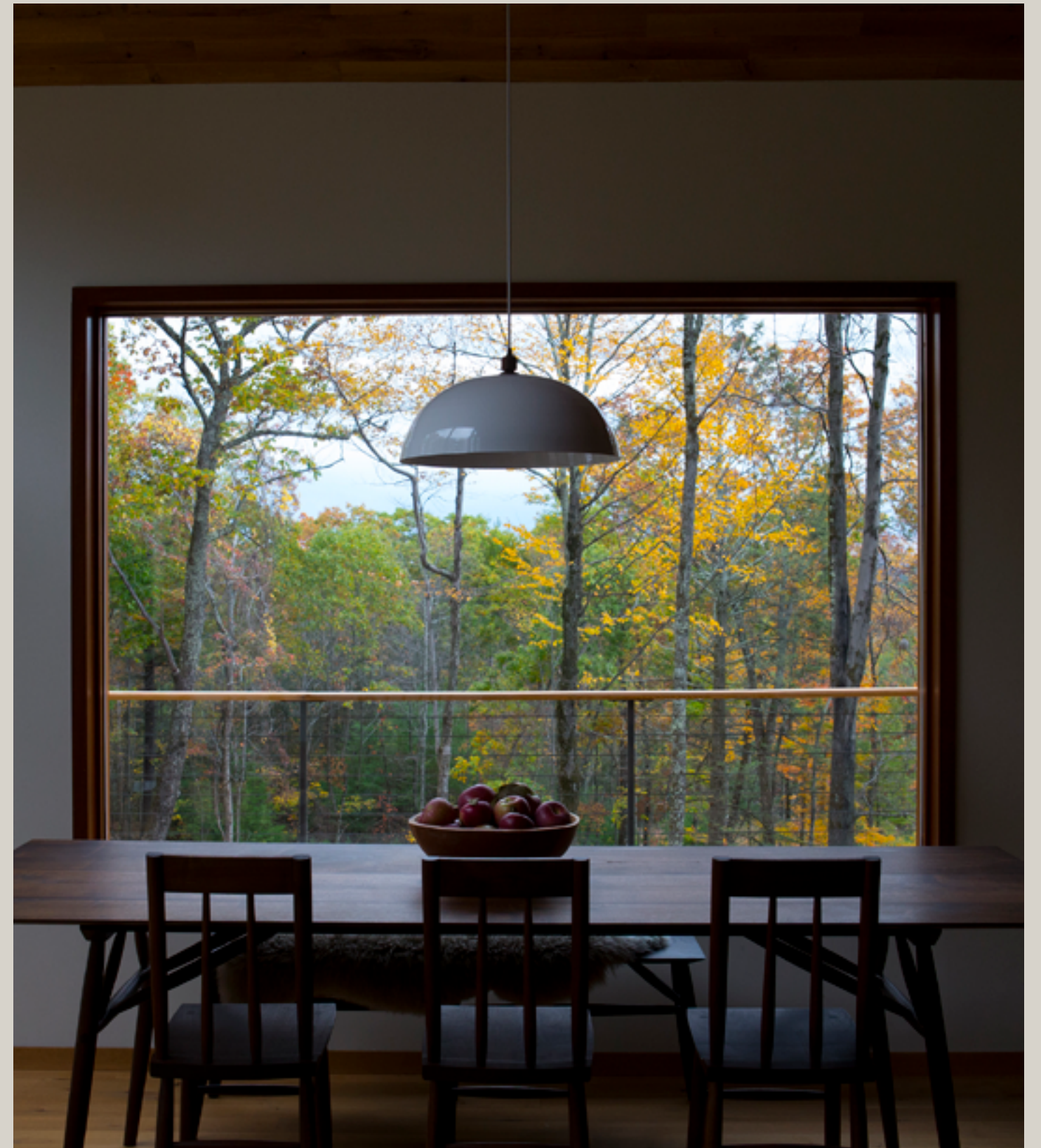



The bedrooms offer a blank canvas for the furnishings to take center stage. We kept things simple once more to allow the large picture window views of the trees to take center stage. A door off the master bedroom leads to the wrap-around deck, inviting the occupant outside on warm, Summer days.

A cedar-paneled walk-in closet is situated in the far corner. Pictured at right, we used a Japanese step-stool from Wickham Solid Wood Studio as a bedside table and included a touch of softness with a small sheep skin rug.

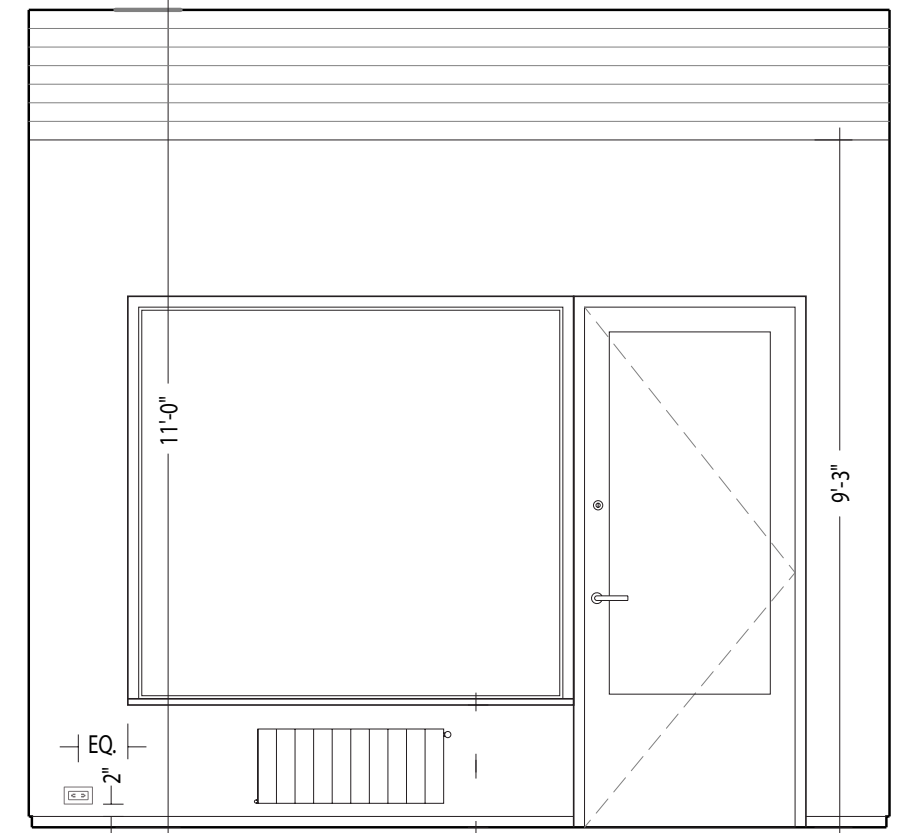

Throughout the house are a number of mid-century modern furniture pieces. Pictured in the images at left, the bedside dresser is mid-century modern piece from Scandinavian Grace, a shop located just 12 miles from Hudson Woods with an eclectic mix of designed furniture and objects. The bed is also a mid-century piece, from the curated collection of our partner, William Lee. Standing adjacent to the bed is the Swell stool from FERN, that we also used in the master bathroom. A photograph from art photographer Uta Barth hangs just over the bed. Altogether, we sought to create a relaxing space filled with small comforts.

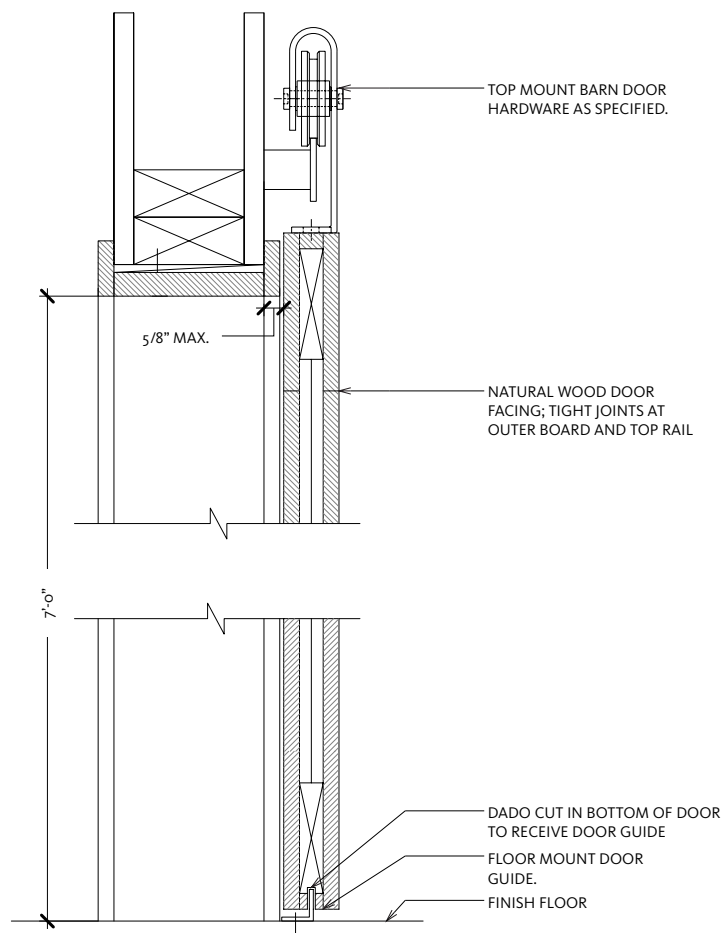
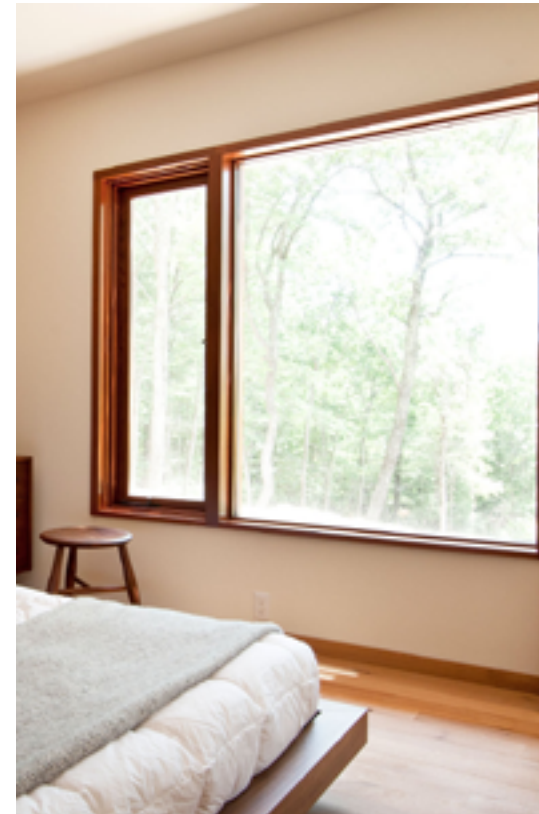



The pool at Hudson Woods is extraordinary, like no other pool we have designed or seen ourselves, and as the pool is opened up once again this season, inspiration and fantasy abounds. Gazing at the pool from within the house and vantage points outside, or being in the pool, floating above the landscape, surrounded by forest and sky all makes for a magical, serene and transportive experience.

Seamlessly integrated with the landscape, we construct each pool with a palette of bluestone pavers and dry-laid bluestone walls, a gunnite structure and integrally colored plaster finish. The siting and particular character of each pool varies based on careful optimization of site conditions. Salt water, heat, indigenous plantings, illumination and pathways to and from the pool take the experience even further.

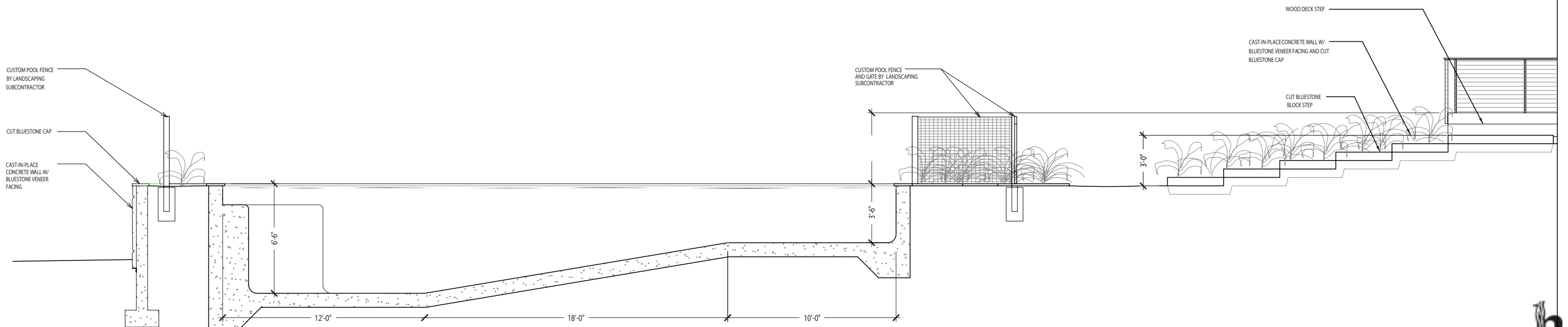
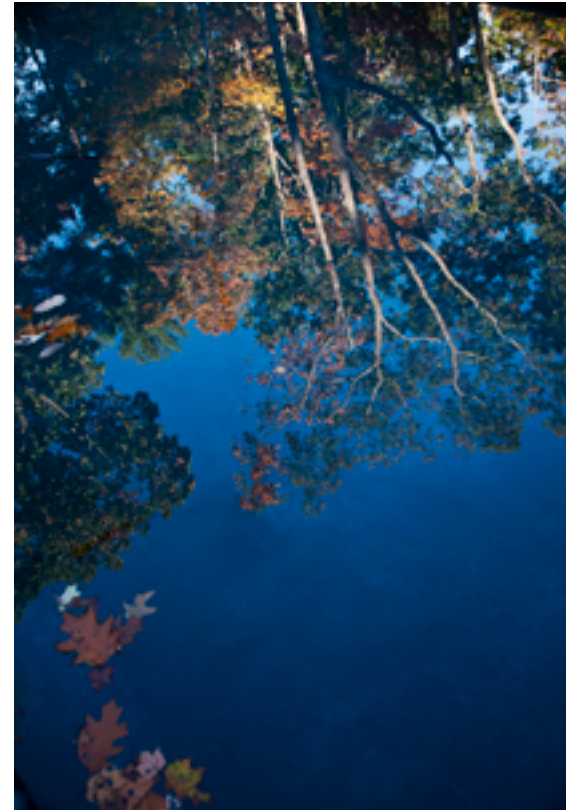





Pictured on these pages is the Pool house upgrade. This amenity includes ample space for a small indoor seating area, and a full kitchen for easy entertaining. The floor-to-ceiling wood windows slide away to facilitate summer pool parties and entertaining. An outdoor shower is tucked away in the far corner.

At left, an owner opted to include both a cold plunge pool and hot tub for all seasons.

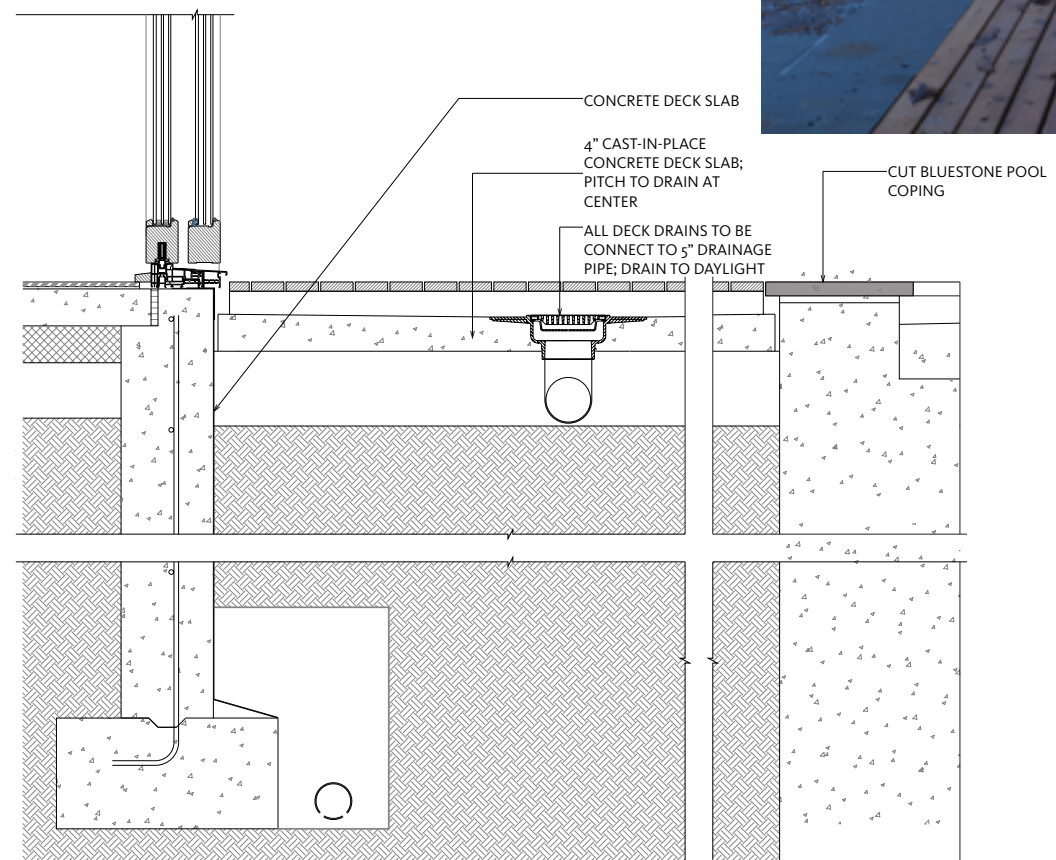
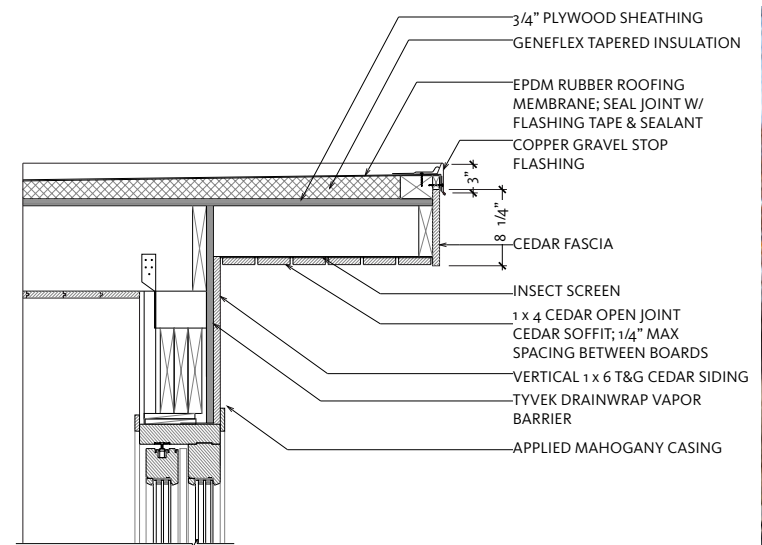
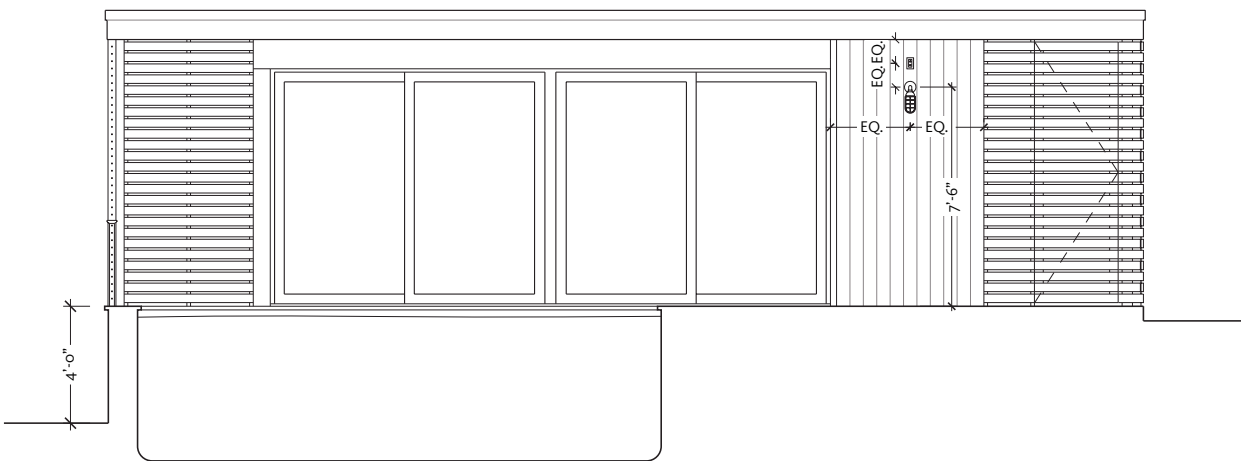







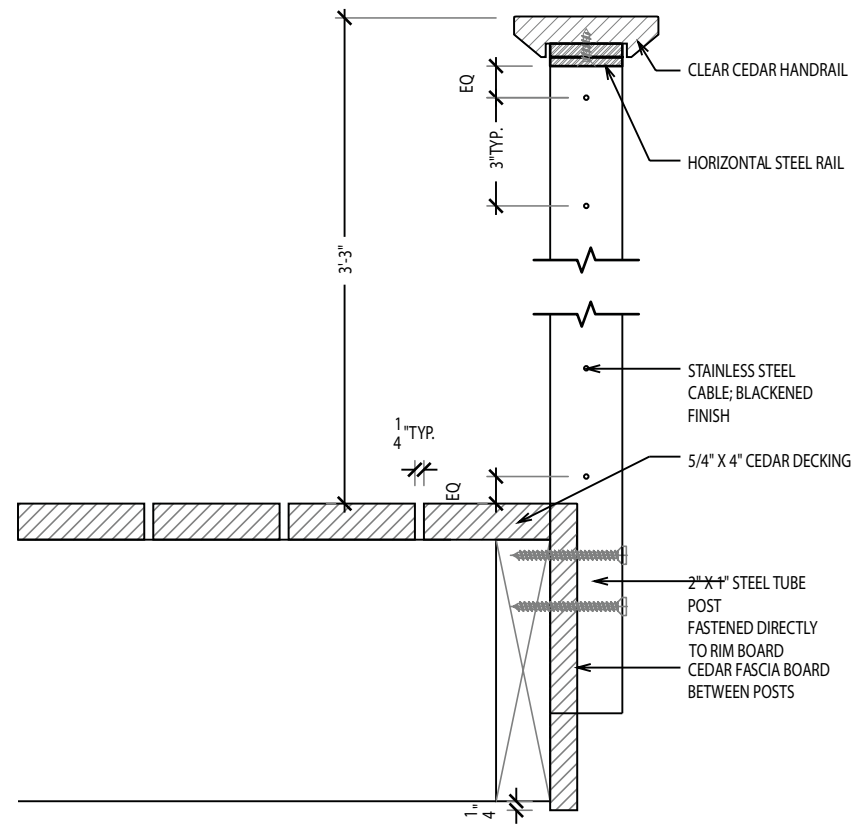

It was important that the railings at Hudson Woods be elegant but quiet. We did not want them to obscure any of the spectacular forest and mountain views. We decided to construct them using a post-and-cable system, keeping sightlines minimally interrupted. The successful assembly and detailing of the powder-coated steel posts we left in the expert hands of collaborator Andrew Becker.

Firepit



Many of our Hudson Woods homeowners are designers in their own right. The firepit pictured here is an example of a personal endeavor taken on by owner Bruce Bell, in collaboration with landscape designer, Aja Hudson.

At the model house, we also designed our own version (pictured at right) of a fire pit that exists above ground. Similarly we chose to have it fabricated from Corten steel. We love seeing how this material weathers overtime, ultimately taking on a beautiful patina.

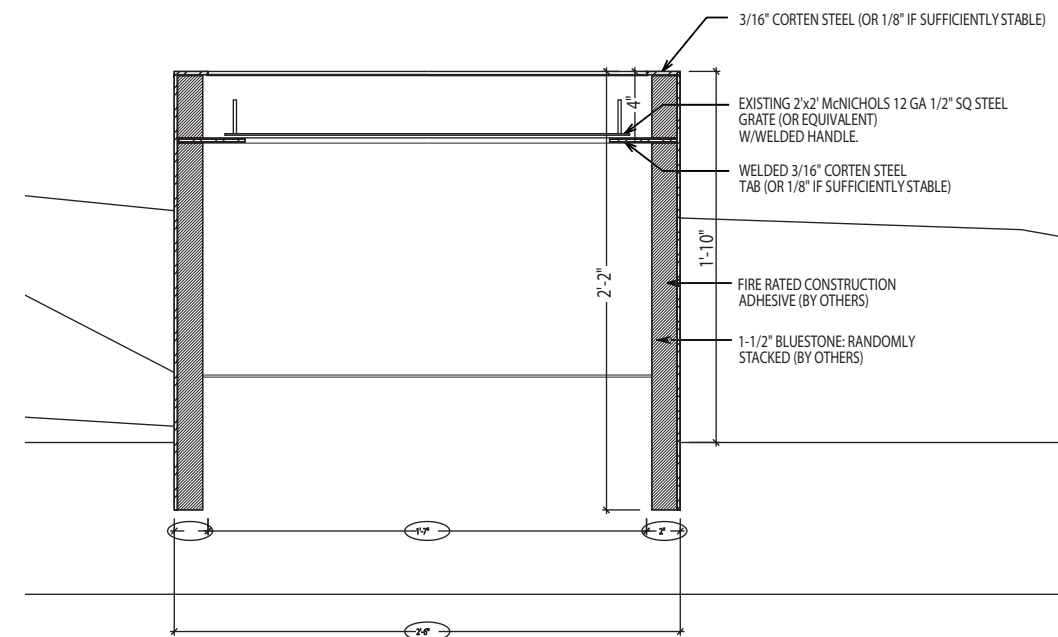



Credits

PHOTOGRAPHY CREDITS:

© Robert Andersen: 86

Jordi Biosca: 2, 14, 92-93, 94, 100, 102

Ty Cole: Intro, Acknowledgements, 12-13, 15, 22, 29, 32, 33, 45, 48, 60, 67, 88-89, 95, 96-97, 98-99, 107

Deborah DeGraffenreid: 23, 25, 28, 44, 55, 65, 66, 82, 84, 87, 90, 91

Dzierlenga F+U: 8, 9

Lance Foley: 61, 79

Nicole Franzen: 52, 53, 74, 79, 85, 87 (right)

Alice Gao: 50, 78

Jay Guillion: 10

Beth Kirby: 54, 69, 83

Lang Studio: Cover, 6-7, 19, 40, 62-63, 64, 70-71

Andrew Montgomery: Partners

Sheena Murphy: 16, 17

James Murray: 39

Michael O'neal: 20-21, 103, 104-105

Michael Robbins: 24

Melissa Shelton: 42, 43, 72-73

Tara Sgroi: 05, 81

Rikki Snyder: 1, 18, 33, 34, 41, 46-47, 68

Joe St Pierre: 11, 76, 77

USM Modular: 56, 57

Matthew Williams: 59



Please freely share and reproduce book content.
When you do so, please credit LANG Architecture and our partners.

© 2019 LANG Architecture
Design by Starr Law and Drew Lang

For questions go to www.hudsonwoods.com
or email us at inquiries@langarchitecture.com

LANG

285 West Broadway Suite 300
New York New York 10013
212-233-9187

langarchitecture.com
hudsonwoods.com

